

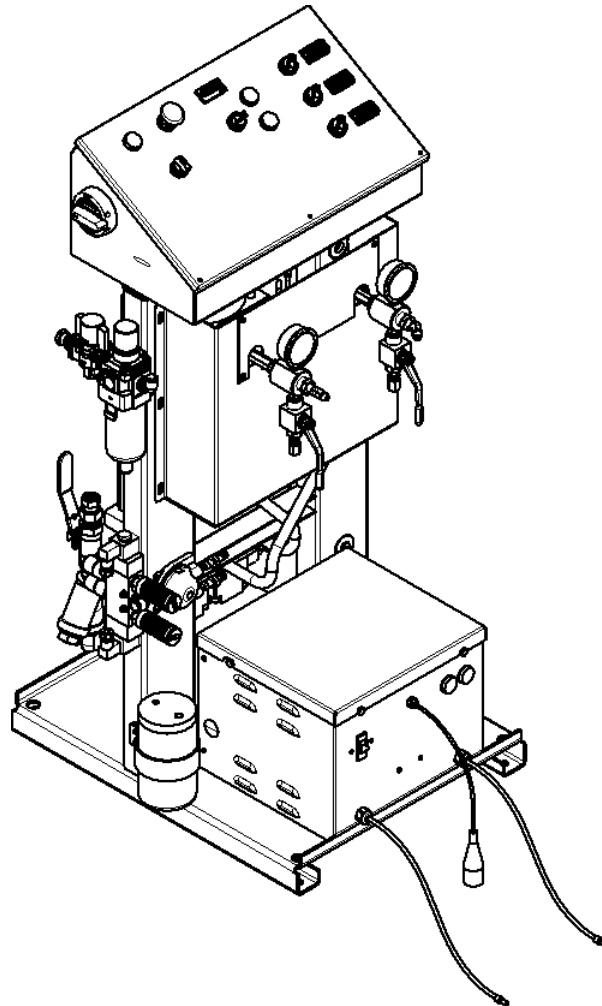

POLYURETHANE
MACHINERY CORPORATION

PK-25 Proportioner Service Manual

Ref. # 202977
Revision 1.3



FOR PROFESSIONAL USE ONLY

Not approved for use in European explosive atmosphere locations



1 Komo Dr.
Lakewood, NJ 08701
Phone: 732-415-4400
URL: <http://www.polymacusa.com>

Table of Contents

1	WARRANTY	4
2	SAFETY AND HANDLING	6
3	CHARACTERISTICS	8
3.1	PRINCIPAL HEATING SYSTEM	8
3.2	HOSE HEATING SYSTEM	8
3.3	DOUBLE ACTING OPPOSED PISTON METERING PUMPS.....	10
3.4	PRESSURE BALANCE CONTROL SYSTEM.....	10
4	TECHNICAL SPECIFICATIONS	11
4.1	ELECTRICAL.....	11
4.2	MECHANICAL.....	12
5	DESCRIPTION	13
6	INSTALLATION	18
6.1	HEATED HOSE INSTALLATION.....	19
6.2	HOSE HEAT TRANSFORMER.....	22
7	PROPORTIONER PURGING	23
8	DIGITAL TEMPERATURE CONTROLLER	25
9	START-UP	27
10	SHUT-DOWN	28
10.1	SHORT-TERM.....	28
10.2	LONG-TERM.....	28
11	TROUBLESHOOTING	29
11.1	HEATERS.....	30
11.2	PNEUMATIC DRIVE SYSTEM.....	33
11.3	METERING PUMP-LINE.....	35
11.4	HOSE HEATING.....	38
12	MAINTENANCE	41
12.1	INLET MATERIAL SCREENS.....	42
12.2	ISO LUBRICATION SYSTEM.....	43
12.3	METERING PUMP-LINE.....	44
12.4	PUMP SEAL REPLACEMENT.....	44
12.5	MATERIAL HEATER.....	45
12.6	THERMOCOUPLE REPLACEMENT.....	45
13	PARTS IDENTIFICATION	47
13.1	A & R SINGLE PUMP ASSEMBLY.....	47
13.2	PUMP-LINE SEAL ORIENTATION.....	49

13.3	PUMP-LINE ASSEMBLY.....	50
13.4	Y-STRAINER ASSEMBLY "A" SIDE	52
13.5	Y-STRAINER ASSEMBLY "R" SIDE	53
13.6	HEATER ASSEMBLY	54
13.7	FINAL ASSEMBLY	56
13.8	PK-25 HOSES	61
13.9	LUBE BOTTLE COMPONENTS.....	62
13.10	BLEED VALVE KIT	63

List of Figures

1	Hose Heating Diagram	8
2	Pressure Balance Control Logic Diagram.....	10
3	Proportioner Dimensions.....	12
4	Component Identification - Front.....	13
5	Component Identification - Back.....	14
6	Front Panel Description.....	16
7	Temperature Sensing Unit.....	20
8	Transformers.....	22
9	Pneumatic Drive System.....	33
10	Metering Pump-Line (202879).....	35
11	A & R Single Pump Assembly (202880/202881).....	47
12	A & R Single Pump Cross Section.....	48
13	A & R Single Pump Assembly Detail A.....	49
14	A & R Single Pump Assembly Detail B.....	49
15	Pump-Line Assembly (202879).....	50
16	Y-Strainer Assembly "A" Side (202599).....	52
17	Y-Strainer Assembly "R" Side (202600).....	53
18	Heater Assembly, PK-25 - A.....	54
19	Heater Assembly, PK-25 - B.....	54
20	PK-25 Final Assembly - A.....	56
21	PK-25 Final Assembly - B.....	57
22	PK-25 Final Assembly - C.....	58
23	Proportioner Hoses.....	61
24	Lube Bottle Assembly.....	62
25	Bleed Valve Kit (202456).....	63

1 WARRANTY

Polyurethane Machinery Corporation (hereinafter “PMC”) provides this **LIMITED WARRANTY** (hereinafter “Warranty”) to the original purchaser (hereinafter “Customer”) covering this equipment and the original PMC manufactured accessories delivered with the equipment (hereinafter “Product”) against defects in material or workmanship of the Product (hereinafter “Defect” or “Defective”) for a period of one (1) year from the date of first purchase as shown on the original PMC invoice (hereinafter “Warranty Period”)

If during the Warranty Period under normal use, the Product is suspected by Customer to be Defective in material or workmanship, it is Customer’s responsibility to contact PMC and return the Product to PMC as directed by PMC, freight prepaid. If PMC determines that the Product is Defective and that such Defect is covered by this Warranty, PMC will credit Customer for the reasonable freight charges incurred by Customer in returning the Defective Product to PMC, and PMC (or its authorized agent) will, at PMC’s option, repair or replace the Product, subject to the following:

1. Original Invoice: The original invoice must be kept as proof of the date of first sale and the Product serial number. The Warranty does not cover any Product if the Original Invoice appears to have been modified or altered, or when the serial number on the Product appears to have been altered or defaced.
2. Product Maintenance: It is the Customer’s responsibility to maintain the Product properly. See your maintenance schedule and owner’s manual for details. The Warranty does not cover an improperly maintained Product.
3. Non-PMC Components and Accessories: Non-PMC manufactured components and accessories that are used in the operation of the Product are not covered by this Warranty. Such components and accessories shall be subject to the warranty offered to the Customer, if any, by the original manufacturer of such component or accessory.
4. Other Warranty Exclusions: The Warranty does not cover any Product that PMC determines has been damaged or fails to operate properly due to misuse, negligence, abuse, carelessness, neglect, or accident. By way of example only, this includes:
 - Normal wear and tear.
 - Improper or unauthorized installation, repair, alteration, adjustment or modification of the product.
 - Use of heating devices, pumping equipment, dispensers, or other parts or accessories with the product that have not been approved or manufactured by PMC.
 - Failure to follow the operating instructions and recommendations provided by PMC.
 - Cosmetic damage.
 - Fire, flood, “acts of God,” or other contingencies beyond the control of PMC.

THE WARRANTY DESCRIBED HEREIN IS THE EXCLUSIVE REMEDY FOR THE CUSTOMER AND IS IN LIEU OF ALL OTHER WARRANTIES, EXPRESS, IMPLIED, STATUTORY OR OTHERWISE, AND THE IMPLIED WARRANTIES OF MERCHANTABILITY AND FITNESS FOR A PARTICULAR PURPOSE AND ALL OTHER WARRANTIES ARE HEREBY DISCLAIMED. TO THE FULLEST EXTENT PERMITTED BY LAW, PMC SHALL NOT BE RESPONSIBLE, WHETHER BASED IN CONTRACT, TORT (INCLUDING, WITHOUT LIMITATION, NEGLIGENCE), WARRANTY OR ANY OTHER LEGAL OR EQUITABLE GROUNDS, FOR ANY CONSEQUENTIAL, INDIRECT, INCIDENTAL, LOST PROFITS, SPECIAL, PUNITIVE OR EXEMPLARY DAMAGES, WHETHER TO PERSON OR PROPERTY, ARISING FROM OR RELATING TO THE PRODUCT, EVEN IF PMC HAS BEEN ADVISED OF THE POSSIBILITY OF SUCH LOSSES OR DAMAGES.

- Non-Warranty Service by PMC: If PMC determines that the suspected Defect of the Product is not covered by this Warranty, disposition of the Product will be made pursuant to the terms and conditions of PMC's written estimate on a time and materials basis.
- Continuing Warranty for Products Repaired or Replaced under Warranty: Following the repair or replacement of a Product covered by this Warranty, such Product will continue to be subject to the original Warranty for the remainder of original Warranty Period or for three (3) months from the repair or replacement date, whichever is longer.
- No Rights Implied: Nothing in the sale, lease or rental of any Product by PMC shall be construed to grant any right, interest or license in or under any patent, trademark, copyright, trade secret or other proprietary right or material owned by anyone; nor does PMC encourage the infringement of same.
- Exclusive Warranty: This writing is the final, complete, and exclusive expression of the Warranty covering the Product. Any statements made by PMC, its employees or agents that differ from the terms of this Warranty shall have no effect. It is expressly understood that Customer's acceptance of this Warranty, by performance or otherwise, is upon and subject solely to the terms and conditions hereof, and any additional or different terms and conditions proposed or expressed by Customer or anyone, whether in writing or otherwise, are null and void unless specifically agreed to in writing by an Officer of PMC.

2 SAFETY AND HANDLING

This chapter contains important information on the safety, handling, and use of your PK Series Proportioner.



Before installing the PK Series Proportioner and start-up, carefully read all the technical and safety documentation included in this manual. Pay special attention to the information in order to know and understand the operation and the conditions of use of the PK Series Proportioner. All of the information is aimed at improving user safety and avoiding possible breakdowns from the incorrect use of the PK Series Proportioner.

WARNING! Symbol is presented in front of information to alert of a situation that might cause serious injuries if the instructions are not followed.

CAUTION! Symbol is presented in front of information that indicates how to avoid damage to the proportioner or how to avoid a situation that could cause issues.

NOTE! Symbol is presented in front of relevant information of a procedure being carried out.

Careful study of this manual will enable the operator to know the characteristics of the PK Series Proportioner and the operating procedures. By following the instructions and recommendations contained herein, you will reduce the potential risk of accidents in the installation, use, and maintenance of the PK Series Proportioner. You will provide a better opportunity for greater output, incident-free operation for a longer time, and the possibility of detecting and resolving problems quickly and simply.





Keep this Operations Manual for future consultation of useful information at all times. If you lose this manual, ask for a new copy from your PMC Service Center or go on line at our website (www.polymacusa.com).

The PK Series Proportioner has been designed and built for the application of polyurea chemical systems, polyurethane foam chemical systems, and some two-component epoxy systems

WARNING! The design and configuration of the PK Series Proportioner does not allow its use in potentially explosive atmospheres or the pressure and temperature limits described in the technical specifications of this manual to be exceeded.

Always use liquids and solvents that are compatible with the unit. If in doubt, consult your authorized PMC distributor.

When working with the PK Series Proportioner, it is recommended that the operator wear suitable clothing and elements of personal protection, including, without limitation, gloves, protective goggles, safety footwear and face masks. Use breathing equipment when working with the PK Series Proportioner in enclosed spaces or in areas with insufficient ventilation. The introduction and follow-up of safety measures must not be limited to those described in this manual. Before starting up the PK Series Proportioner, a comprehensive analysis must be made of the risks derived from the products to be dispensed, the type of application, and the working environment.

	<p>To prevent possible injury caused by incorrect handling of the raw materials and solvents used in the process, carefully read the Material Safety Data Sheet (MSDS) provided by your supplier. Deal with the waste caused according to current regulations.</p>
	<p>To avoid damage caused by the impact of pressurized fluids, do not open any connection or perform maintenance work on components subject to pressure until the pressure has been completely eliminated.</p>
	<p>Use suitable protection when operating, maintaining or being present in the area where the equipment is functioning. This includes, but is not limited to, the use of protective goggles, gloves, shoes and safety clothing and breathing equipment.</p>
	<p>The equipment includes components that reach high temperatures and can cause burns. Hot parts of the equipment must not be handled or touched until they have cooled completely.</p>
	<p>To prevent serious injury through crushing or amputation, do not work with the equipment without the safety guards installed on the moving parts. Make sure that all the safety guards are correctly reinstalled at the end of the repair or maintenance work of the equipment.</p>

3 CHARACTERISTICS

The PK Series Proportioner has been designed and built for the application of polyurea chemical systems, polyurethane foam chemical systems, and some specific two-component epoxy systems.

3.1 PRINCIPAL HEATING SYSTEM

The Proportioner consists of one (1) Material Heater without internal seals. The Low Pressure Heater has three (3) Heating Elements per fluid side rated at 1,250, 1,500, or 1750 watts, each giving the Proportioner a total heat output of 7,500, 9,000, or 10,500 watts. The High Pressure Heater has four (4) Heating Elements per fluid side rated at 1750 watts, each giving the Proportioner a total heat output of 14,000 watts. Every heating system provides the necessary control and safety components for their precise operation. The Material Heater design allows for a controlled and precise temperature differential (ΔT) and material application temperatures of up to 190° F under ambient temperatures.

3.2 HOSE HEATING SYSTEM

The system is designed with a 3 KVA Isolation Transformer that enables effective heating of up to a total hose length of 310 feet (also available with a 2KVA transformer and a 5 KVA transformer for maximum hose lengths of 210 and 410, respectively). The system includes an innovative hose heating concept in which the continuous braid tinned-copper jacket is distributed evenly around the circumference of the hose providing a uniform heating watt density and precise control of the material application temperature. This hose heating element design is extremely resistant to fatigue failure.

100% circumferential coverage produces the most uniform distribution of heat available.



Figure 1: Hose Heating Diagram

HIGH PRESSURE (3500 PSI) WHIP	
PART NUMBER	DESCRIPTION
MA-00040A	1/4" x 10' WHIP HOSE, HP
MA-00040A-25	1/4" x 25' WHIP HOSE, HP W/SCUFF
MA-00040-50	1/4" x 50' WHIP HOSE, HP W/SCUFF

LOW PRESSURE (2250 PSI) HOSE WITHOUT SCUFF	
PART NUMBER	DESCRIPTION
MA-00014A	3/8" x 50' HOSEASY,LP,NO TC
MA-00014A-TC	3/8" x 50' HOSEASY,LP,W/TC
MA-00014A-25	3/8" x 25' HOSEASY,LP,NO TC
MA-00014A-TC-25	3/8" x 25' HOSEASY,LP,W/TC
200001	3/8" x 50' HOSEASY,LP,W/RTD
200010	1/2" x 50' HOSEASY,LP,NO TC
200011	1/2" x 50' HOSEASY,LP,W/TC
200012	1/2" x 50' HOSEASY,LP,W/RTD

LOW PRESSURE (2250 PSI) HOSE WITH SCUFF	
PART NUMBER	DESCRIPTION
200002	3/8" x 50' HOSEASY,LP,W/RTD,W/SCUFF
200005	3/8" x 50' HOSEASY,LP,NO TC,W/SCUFF
200006	3/8" x 50' HOSEASY,LP,W/TC,W/SCUFF
200016	1/2" x 50' HOSEASY,LP,NO TC,W/SCUFF
200017	1/2" x 50' HOSEASY,LP,W/TC,W/SCUFF
200018	1/2" x 50' HOSEASY,LP,W/RTD,W/SCUFF

HIGH PRESSURE (3500 PSI) HOSE WITHOUT SCUFF	
PART NUMBER	DESCRIPTION
MA-00039A	3/8" x 50' HOSEASY,HP,NO TC
MA-00039A-TC	3/8" x 50' HOSEASY,HP,W/TC
MA-00039A-25	3/8" x 50' HOSEASY,HP,NO TC

HIGH PRESSURE (3500 PSI) HOSE WITH SCUFF	
PART NUMBER	DESCRIPTION
200007	3/8" x 50' HOSEASY,HP,NO TC,W/SCUFF
200019	1/2" x 50' HOSEASY,HP,NO TC,W/SCUFF
200224	1/2" x 50' HOSEASY,HP,W/TC,W/SCUFF

3.3 DOUBLE ACTING OPPOSED PISTON METERING PUMPS

The opposed double acting Pump Line is driven by a double ended Hydraulic Cylinder. The in-line pump system with opposed piston pumps provides a constant volume and guarantees uniform pressures in both directions of pump movement.

3.4 PRESSURE BALANCE CONTROL SYSTEM

The Pressure Balance Control (PBC) system performs an automatic shutdown when a chemical imbalance occurs. When the system is turned off, the Proportioner will perform as if there is no PBC system and will continue pumping material. When the system is turned on, it will continually monitor the pressure between the two chemicals (known as the **pressure differential**). If the pressure differential becomes equal to or greater than the **maximum allowable pressure differential**, the pumps will be shut off.

The Pressure Balance Control system can be simplified into a logic box diagram with inputs and outputs. There are five inputs: the power supply from the main console, the pressure readings from each chemical, the maximum pressure, and the maximum allowable pressure differential. Inside the logic box, the actual pressure differential of the chemicals is compared to the maximum allowable pressure differential. Depending on the circumstances of all five inputs, there are only two possible outputs: either the pumps will continue to pressurize and move material, or the pumps will shut off and flow will be lost.

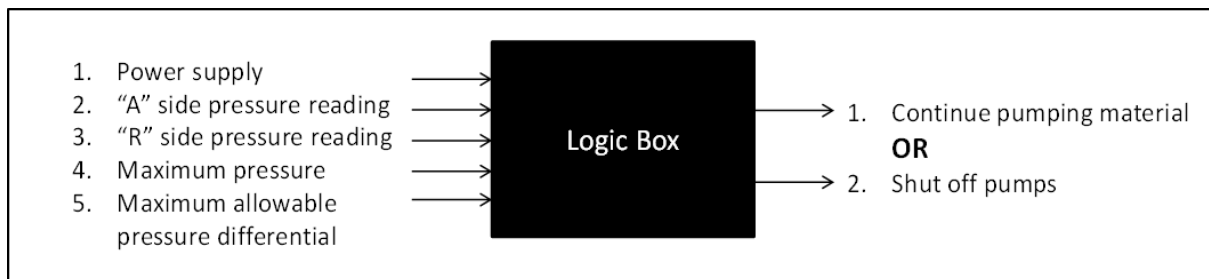

Figure 2: Pressure Balance Control Logic Diagram

4 TECHNICAL SPECIFICATIONS

4.1 ELECTRICAL

PK-25, Three Phase, 208-240V

Pressure	Heater Size	Electrical Consumption
2,000PSI	7.5kW(3.75kW/side)	26A

Material Heater Power	Power Consumption
7.50kW/side(3x1250W/side)	7.5kW
Hose Transformer	Power Consumption
70V	2KVA



CAUTION! Inside the console is a Terminal Strip for connecting the main power (wire not supplied) to the PK Series Proportioner. This electrical connection must be made only by a qualified electrician.

4.2 MECHANICAL

123 Pumps	
Maximum Working Pressure	2,000PSI(14MPa, 138bar)
Maximum Production Output	25lb/min(14kg/min)
Minimum Production	2lb/min(1kg/min)
Gallons per Cycle (Single Pump)	0.01859gal/cycle(0.07037L)
Cycles per 55gal(208L) Drum	2,958cycles
Maximum Hose Length	
2KVA Transformer	210ft(64m)
Approximate Weight	
300lbs(136kg)	
Overall Dimensions(W x D x H)	
25in x 25in x 48in (64cm x 64cm x 123cm)	

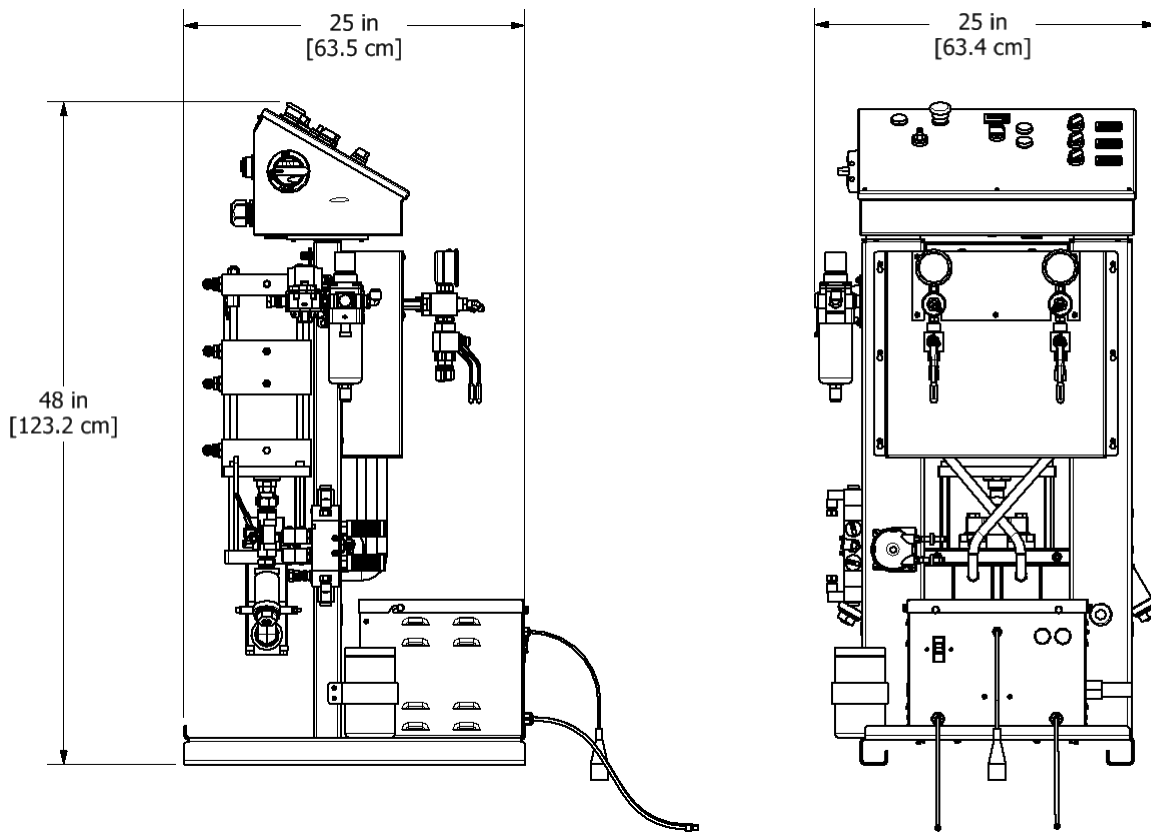

Figure 3: Proportioner Dimensions

5 DESCRIPTION

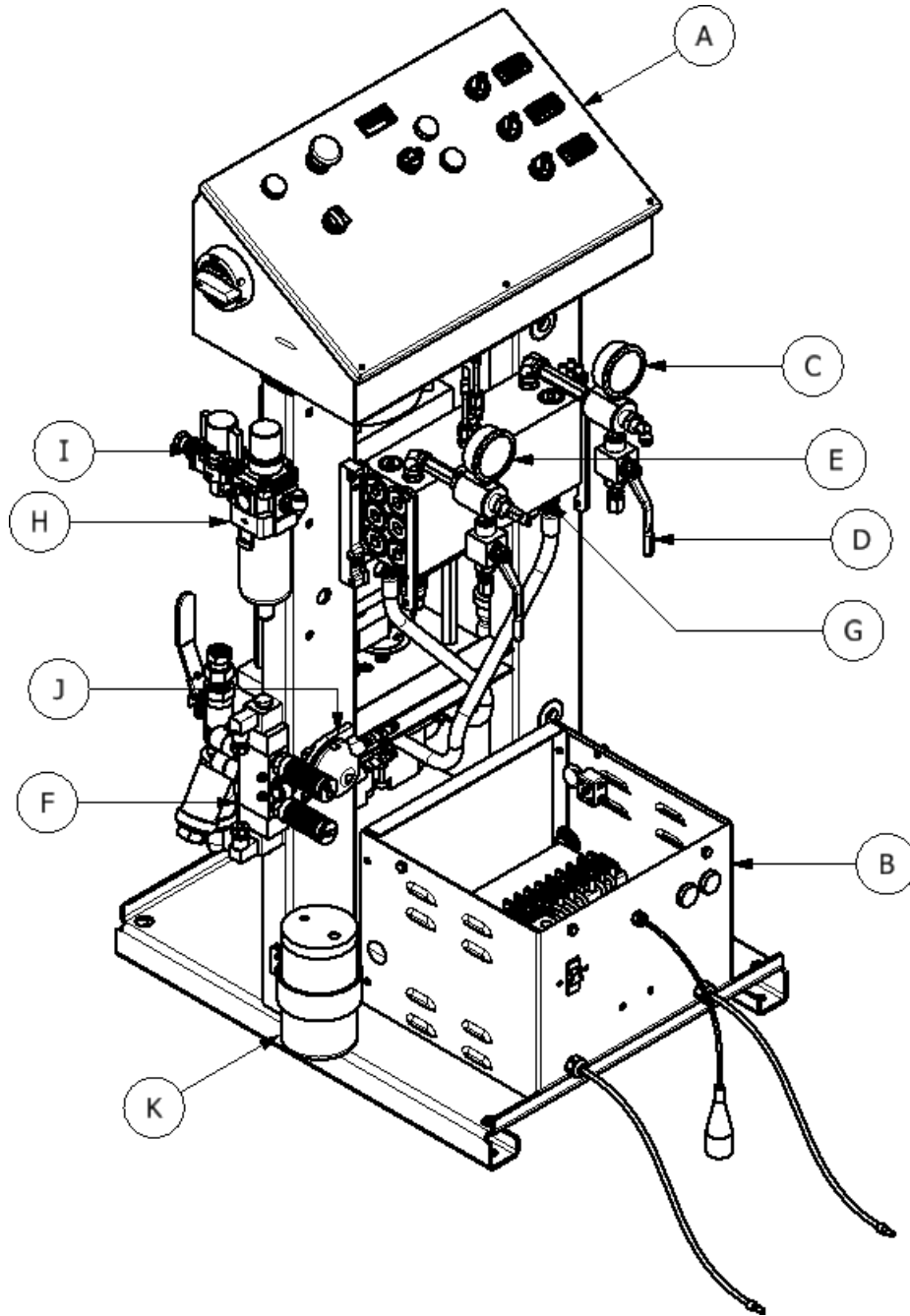

Figure 4: Component Identification - Front

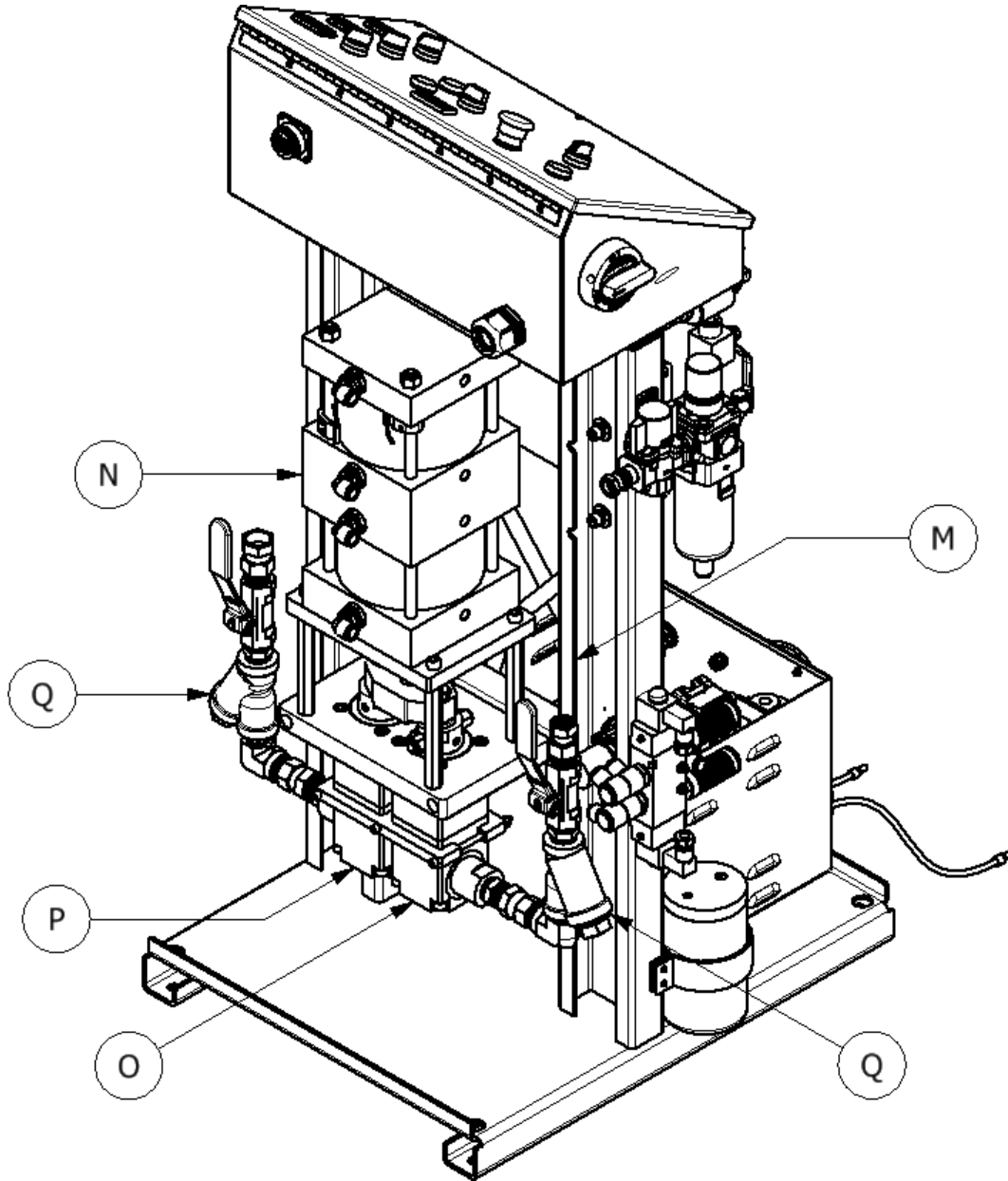

Figure 5: Component Identification - Back

A. Control Panel

Controls and regulates the operation of the PK Series Proportioner.

B. Hose Heating Transformer

Supplies the required voltage for material Heated Hoses.

C. Polyol (Poly, "R" Side) Exit Pressure Gauge

Displays the pressure of the heated "R" Side material exiting the Proportioner and entering the Heated Hose.

D. Recirculation (Recirc) Valves

Separate ball valves for both the "A" and "R" sides that allows the user to recirculate material back into the respective barrel for reheating purposes or to purge the Proportioner of remaining material. Recirculation valves are standard on all PK Series Proportioners.

E. Isocyanate (Iso, "A" Side) Exit Pressure Gauge

Displays the pressure of the heated "A" Side material exiting the Proportioner and entering the Heated Hose.

F. Pneumatic Solenoid Valve

Solenoid that controls air flow to pistons inside Multi Stage Air Cylinder.

G. Primary Heater

Heats up each chemical to the set-point input by the user. An E-type thermocouple is installed on each side of the Pre-Heater to read the actual temperature of the material.

H. Air Pressure Regulator

Allows the pressure of the incoming air to be increased or decreased which in turn will adjust the static pressure of the machine.

Pull up to unlock. Turn CLOCKWISE to increase the pressure and COUNTERCLOCKWISE to decrease. Push down to lock.

I. Incoming Air Valve

Main valve for incoming compressed air. Attach incoming 1/2" air line to the supplied 3/8" NPTF Swivel fitting.

OPEN - Press down on red knob and turn CLOCKWISE to open.

CLOSED - Press down on red knob and turn COUNTERCLOCKWISE to close.

J. Isocyanate (Iso, "A" Side) Lube Pump

24 VDC peristaltic pump that pumps PMC approved lubricant from the "A" Side Lube Reservoir to the "A" Side Pump Shaft. The Lube Pump will cycle whenever the Pump Line enters the RETRACT stroke.

K. Isocyanate (Iso, "A" Side) Lube Reservoir

Provides PMC approved lube to the "A" Side Pump Shaft to avoid crystallization build-up

L. Multi Stage Air Cylinder

Operates both Metering Pumps simultaneously via air pressure incoming from Pneumatic Solenoid Valve.

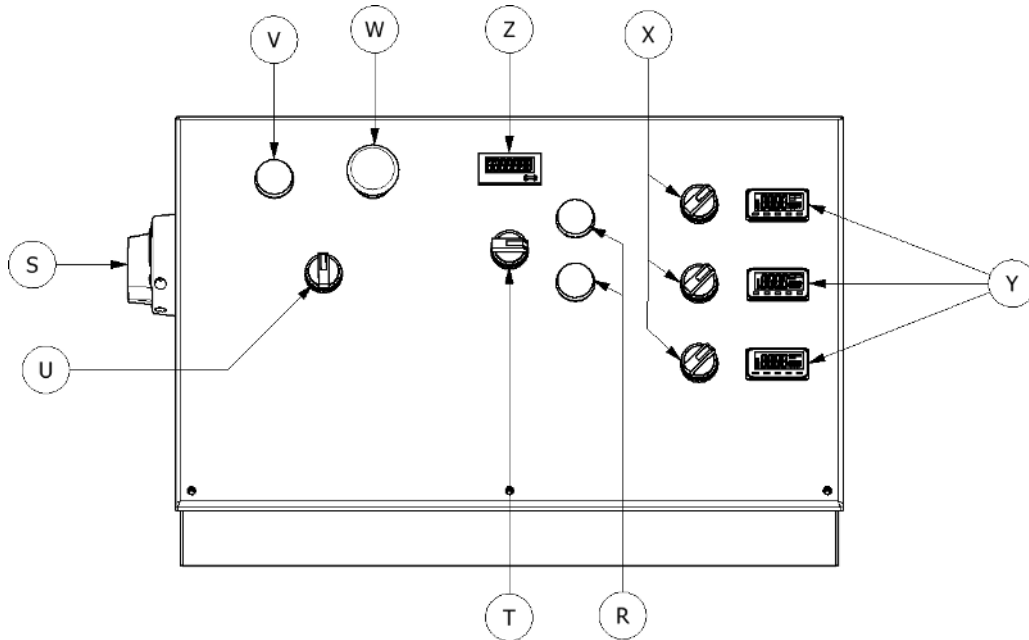

Figure 6: Front Panel Description

M. Isocyanate (Iso, "A" Side) Inlet

1/2" NPTF swivel fitting to connect to ISO supply hose and a ball valve to control flow.

N. Polyol (Poly, "R" Side) Inlet

3/4" NPTF swivel fitting to connect to POLY supply hose and a ball valve to control flow.

O. Isocyanate (Iso, "A" Side) Metering Pump

Meters the Isocyanate material.

P. Polyol (Poly, "R" Side) Metering Pump

Meters the Polyol material.

Q. Inlet Material Y-Strainer

Filters out debris in material from bulk supply. (Standard filter is 60 mesh)

R. Directional Indicator Lights

Amber lights that indicate the stroke direction of the Metering Pumps.

Normal - Right indicator light. Indicates pumps are moving towards Normal position.

Retract - Left indicator light. Indicates pumps are moving towards Retract position.

If excessive pressure is monitored in the system, the pump circuit will be disabled and the Directional Indicator Lights will shut off.

S. Main Power Switch

Turns ON and OFF main power to the control panel. It must be turned ON for any operation to be performed with the unit.

The Green indicator light (V, page 16) indicates that the main power switch is ON.

T. Pump Switch

Off - Removes power from the pump circuit. The directional indicator lights will not be lit.

Normal - Activates the normal operation of the machine. When the switch is ON, the directional light corresponding to the stroke direction will light.

Retract - Sets the Piston Rod of the Iso (A) metering pump into the pump to prevent crystallization of Iso (A) on the Piston Rod. Press the RETRACT key every time the unit is stopped by the operator (See Section 10 on page 28).

U. Control Power Switch

Turns the control power ON and OFF to the complete electrical circuit including Primary Heaters and Hose Heating Transformer.

V. Power On Light

Green indicator light indicates whether the Main Power for the machine is turned ON or OFF.

W. Emergency Stop Button

Interrupts the PK-Series control power circuit to stop all motion and heating.

Activate – Press the Emergency Stop Button down to stop all motion and heating.

Deactivate – Twist the Emergency Stop Button CLOCKWISE to release.

X. Heater Temperature Switch ("A" Side (Iso)/"R" Side (Poly)/Hose)

Turns power ON and OFF to each side of the Pre-Heater and the Hose Heating Isolated Transformer. The red switch/indicator light for each heater indicates that heater is ON.

Y. Digital Temperature Controllers

Displays the temperature of the chemicals in the Pre-Heater and Heated Hose. See page 25 for detailed instructions.

Z. Totalizer

Indicates the total number of pump cycles. Use this number to calculate material usage.

Model	Pressure	Pump Size	Cycles per Gal (3.79L)
PK-25	2,000PSI	123	55

6 INSTALLATION

WARNING! Use suitable protection and follow the recommendations in the Safety Information enclosed and provided by material suppliers when installing or working with the Proportioner.

CAUTION! Make sure the power cable is disconnected from the main power source before connecting to the Terminal Strip in the Console.

NOTE! To ensure the PK Series Proportioner works correctly, the electrical supply must meet the specifications indicated on the Serial Number Placard affixed to the Electrical Console.

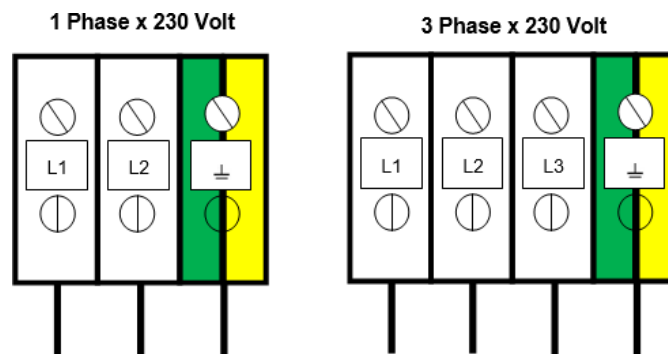

Follow the recommended procedure in the indicated order to install the Proportioner:

1. Fill Isocyanate Lube Reservoir (Item K, page 13) with PMC certified lube
2. Insert the main power cable by passing it through the strain relief at the back of the Control Panel (Item A, page 13)
3. Connect a minimum 1/2" air line to the Incoming Air Valve (Item I, page 13) on the left side of the Control Panel

CAUTION! Ensure that the emergency stop is not engaged.

CAUTION! Ensure Main Power Switch is OFF and incoming power is locked OFF before reversing power leads or performing any maintenance in the electrical cabinet.

6.1 HEATED HOSE INSTALLATION

CAUTION! The material delivery Heated Hoses are color coded Red and Blue, allowing the user to recognize them. The Red corresponds to the Isocyanate (Iso, A) and the Blue to the Polyol (Poly, R). To avoid connection errors, the Coupling Connections of the Iso (A) and Poly (R) Heated Hoses are different sizes to ensure correct orientation.

NOTE! The material delivery Heated Hoses are capped at the ends to prevent absorbing moisture. Do not remove caps until the Heated Hoses are going to be installed on the Proportioner.

1. Lay out all the Heated Hose assemblies end to end aligning the Iso “A” (red) and Poly “R” (blue) and connect the respective Coupling Connections using the appropriate sized open-end wrench after ensuring Heated Hose assemblies lay flat.

CAUTION! Take care to not cross-thread or over-tighten the Coupling Connections. Thread seal tape or compound is not recommended for this tapered seat Coupling Connections.

2. Connect the material Heated Hoses to the outlets of the respective Heaters i.e. Iso (A) Heated Hose to the Iso (A) Heater and the Poly (R) Heated Hose to the Poly (R) Heater ensuring Heated Hose assemblies lay flat.
3. Connect Air Hose Coupling Connections.
4. Connect the Heated Hose power wires to the “Fast-Lock” Connector (Part# KT-00029A) coming from the Hose Heat Transformer as follows:
 - (a) Loosen the Socket Head Set Screw to allow insertion of the Heated Hose electrical wire Terminal.
 - (b) Insert the Terminal into the “Fast-Lock” Connector Body.
 - (c) Securely tighten the Socket Head Set Screw.
 - (d) Install electrical tape around Connector Body.

NOTE! A good practice is to add some dielectric grease (Permatex 67VR or equivalent) to the outside of the Terminal, where the electrical connection is made, prior to insertion.

5. Repeat the above steps to connect the “Fast-Lock” Connectors that you will find on all Heated Hose power wire.

CAUTION! Ensure the proper mechanical and electrical connections of the Heated Hoses are made to avoid possible material leakage and Hose heat problems.

6. It is recommended the TSU be installed between the last section of Heated Hose and the Gun Whip. Carefully straighten the sensing wire, inserting it in the Iso (A) Heated Hose and tighten fluid fittings with appropriate sized open-end wrenches.

CAUTION! To protect the TSU sensor, you must pay special attention not to kink or excessively bend the Heated Hoses. Do not coil the Heated Hoses with a diameter of less than 4 feet (1.22 Meters). (TSU)

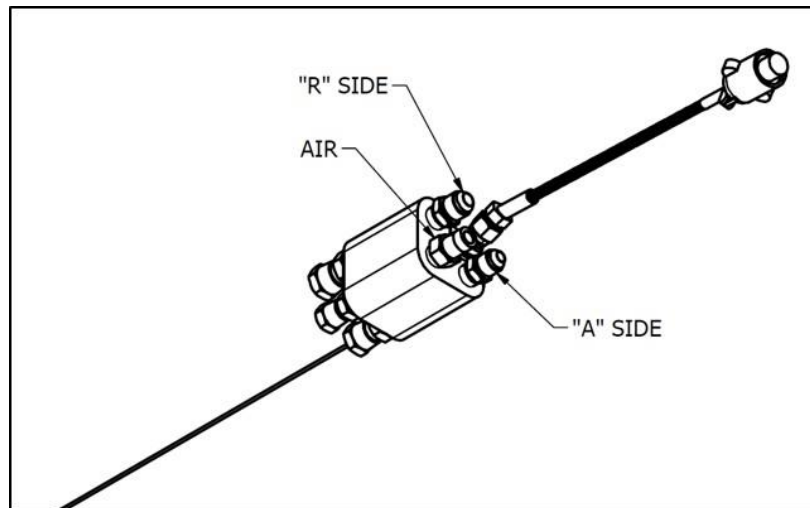

Figure 7: Temperature Sensing Unit

Part# EL-51A-4
Replacement Sensor Part# EL-51A-2

CAUTION! To protect the TSU sensor, you must pay special attention not to kink or excessively bend the Heated Hoses. Do not coil the Heated Hoses with a diameter of less than 4 feet (1.22 Meters).

CAUTION! Connecting the TSU between the first and second section of Heated Hose results in the TSU sensing the material temperature exiting the Heater and not the inside of the Heated Hose near the Spray Gun.

7. Ensure the Manual Valves on the Spray Gun are CLOSED and connect the Coupling Block to the Heated Gun Whip.
8. Ensure the Manual Valves are CLOSED and connect the Coupling Block to the Heated Gun Whip.

CAUTION! Excessive force closing or opening the Manual Valves may result in damage to the Manual Valves and/or Coupling Block.

9. Connect the Transfer Pump/Heated Hose Assemblies/Air Supply and Air Dryer systems as required. Review the Installation Instructions for each to ensure proper set-up and operation.
10. Install the Material Transfer Pumps as follows:

WARNING! If Transfer Pumps have been previously used, pay special attention to connect each Pump to its specific material. Inadvertently changing the Transfer Pumps will cause a chemical reaction rendering them useless.

NOTE! Placing a tape of the same color as of the Material Delivery Hoses (red for the Iso (A), blue for the Poly (R)) on each Transfer Pump would be a good method for minimizing errors in connection.

- a. Make sure that the Inlet Valves on the Proportioner are closed.
- b. Connect one end of the Polyol (R) Material Delivery Hose (3/4" thread) to the Proportioner Polyol (R) Inlet Valve and the other end to the Polyol (R) Transfer Pump.
- c. Connect one end of the Iso (A) Material Delivery Hose (1/2" thread) to the Proportioner Iso (A) Inlet Valve and the other end to the Iso Transfer Pump.
- d. Connect the air hose to the Transfer Pumps after ensuring each Transfer Pump Shut-Off Valve is CLOSED.

NOTE! To avoid errors in connection, the Coupling connections of the Iso (A) and Poly (R) Material Delivery Hoses are different sizes, making it difficult to swap connections.

11. Ground the Transfer Pump as recommend by the material supplier. The movement of product inside the Hoses can cause static electricity and produce electrical discharges.
12. Connect air to the air line coming off the first section of hose (90-110 psi, 6-8 bar)

6.2 HOSE HEAT TRANSFORMER

The Hose Heat Transformer offers the ability of connecting to different output voltages depending on the total length of the Heated Hose in use, maximizing the heating ability of the Heated Hose. The factory setting is 18 volts for use with 60 feet of Heated Hose. Before starting the Proportioner, ensure the setting matches the Heated Hose length installed. If Heated Hose sections are added or removed, the Tap setting should be changed to a setting which will limit the maximum amperage in the Heated Hose to 52 amps. The suggested settings are listed in the table below.

RECOMMENDED TAP SETTINGS		
Tap	Feet	Meters
120V	410	125.0
105V	360	109.7
90V	310	94.5
75V	260	79.5
60V	210	64.0
45V	160	48.8
30V	110	33.5
18V	60	18.3

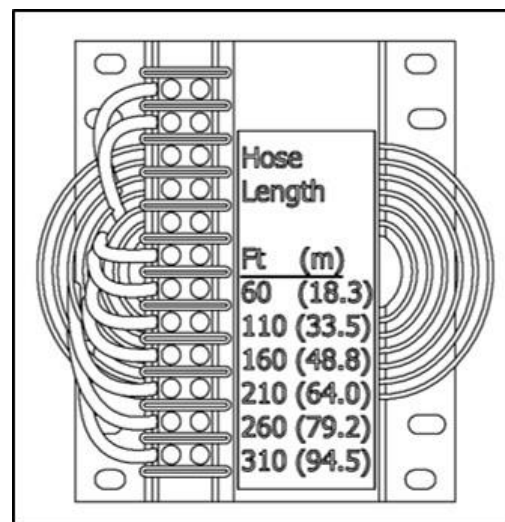
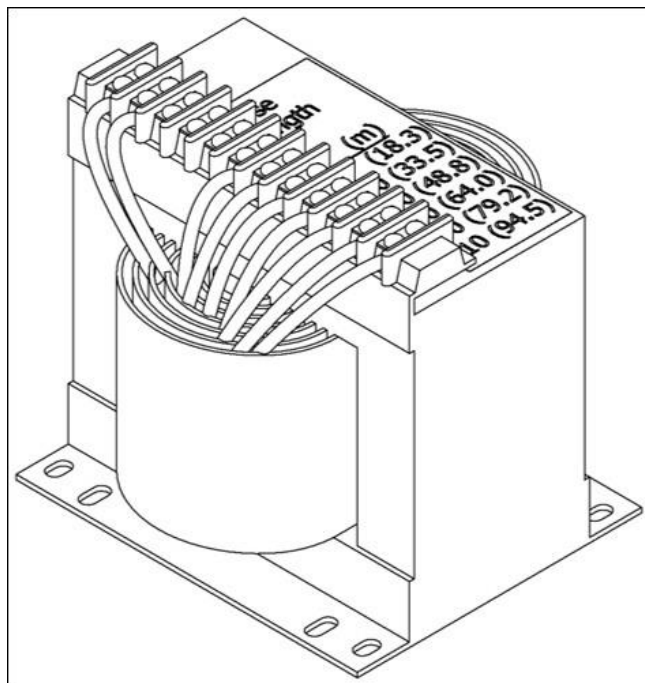

Figure 8: Transformers

*90V transformers (shown above) allow for a maximum hose length of 310 ft (94.5 m). 120V transformers allow for a maximum hose length of 410 ft (125 m).

7 PROPORTIONER PURGING

WARNING! Use suitable Personal Protection Equipment (PPE) and follow the recommendations in the Safety Information provided by product suppliers when installing or working with the unit.

WARNING! Do not turn the Temperature Controllers ON until the Proportioner purging procedure is complete and the Primary Heaters and Heated Hoses are filled with material.

NOTE! Before using the Proportioner it is necessary to purge the entire system, including Heated Hoses of mineral oil left over from Quality Control testing and air. The following procedure is also followed to purge air entrapped by running out of material in the supply Drum/Reservoirs resulting in a significant indicated material pressure imbalance as indicated by the Pressure Gauges and sprayed material.

1. Ensure the following before proceeding:
 - a. Air supply to Transfer Pumps is 90 - 110 psi (6 - 8 bar).
 - b. Proportioner inlet ball valves are CLOSED.
 - c. All connections are tight.
 - d. Material should be stored to the material suppliers recommended temperatures.
 - e. Spray gun coupling block is installed and manual valves are closed.
2. Slowly OPEN the Poly (R) Transfer Pump Air Shut-Off Valve allowing Pump to cycle slowly as it fills the Material Delivery Hose to the Proportioner. Check for leaks.
3. OPEN Poly (R) Coupling Block Manual Valve over a waste container.
4. Slowly OPEN Proportioner Poly (R) Inlet Valve allowing Transfer Pump to move material through the system. When all spitting of air stops and all traces of mineral oil have disappeared, CLOSE Poly (R) Coupling Block Manual Valve. Clean Coupling Block.
5. Repeat steps 2 to 4 for Iso (A) side.

CAUTION! Properly dispose of all waste chemicals in accordance with all applicable local, state and federal codes. DO NOT turn on the Auto Countdown Switch or the Pressure Balance Control Switch.

6. Attach a minimum 1/2" air supply hose via an air compressor capable of outputting a minimum of 15 - 20 scfm (425 - 566 l/min) to the 3/8" NPTF swivel fitting on the INCOMING AIR VALVE.
7. Pull up on the black knob of the Air Pressure Regulator (Item H, page 13) to unlock and turn COUNTERCLOCKWISE to close Regulator completely.
8. Ensure that all air line fittings and hoses are tight.
9. Turn on air compressor or air supply.
10. Open Incoming Air Valve by pressing down on the red knob and turning CLOCKWISE.
11. Turn the black knob of the Air Pressure Regulator CLOCKWISE to increase the air pressure delivered to the Multi Stage Air Cylinder (Item N, page 14) until both the "A" and "R" Side Exit Pressure Gauges (Items C & E, page 13) read approximately 400 psi (27.6 bar). Both gauges should read approximately the same value.
12. Turn ON Main Power Switch (Item S, page 16). The green light will light up (Item V, page 16).
13. Turn ON Control Power Switch (Item U, page 16). The red Switch/Indicator Light will light up.
14. Check all Heated Hose Couplings and TSU connections for leakage. Ensure all terminals are securely fastened.
15. Bundle all Heated Hose Connections ensuring that there are NO kinks in the TSU Cable or Air Hose. Wrap with Electrical Tape to securely hold all components in place and minimize places for bundle to snag onto job site protrusions.

NOTE! It is easier to test for leaks and tighten loose connections at lower pressure. This will in turn reduce any loss of material and decrease the chance of unnecessary chemical reactions.

16. Bundle all Heated Hose Connections ensuring that there are NO kinks in the TSU Cable or Air Hose. Wrap with Electrical Tape to securely hold all components in place and minimize places for bundle to snag onto job site protrusions.

8 DIGITAL TEMPERATURE CONTROLLER

The PK Series has three Digital Temperature Controllers to manage the temperatures for the Primary Heaters (Iso (A), Poly (R)) and the Heated Hose. The Hose Heater Controller is programmed different from the Iso (A) and Poly (R) Controllers and therefore not interchangeable with them.

WARNING! Do not turn the Temperature Controllers ON until the Proportioner Purging procedure is complete and the Primary Heaters and Heated Hoses are filled with material.

OMRON CONTROLLER

1. Press and hold the UP or DOWN keys to **increase** or **decrease**, respectively, the material temperature set-point to the desired value as determined by the material supplier or application conditions.
2. The smaller **green** numbers in the bottom right side of the controller display the set point. The larger **white** numbers in the center of the controller display the actual temperature of the material as read by the thermocouples in the Pre-Heater and TSU assembly. See the image below for the OMRON Heater Controller display.
3. Turn the Heater Temperature Switch (Item X, page 16) to the **right** to turn ON each heater.



NOTE! The Temperature Controller displays the actual material temperature and the set point. The **YELLOW** box with the word **OUT** indicates that the heaters are being powered.

WARNING! The Controllers are factory programmed and are not field re-programmable. If a problem is encountered, contact your PMC Distributor. Do not attempt to change any of the programmed parameters. Do not substitute a Controller from an alternate supplier as its use may result in equipment damage and/or bodily injury.

9 START-UP

NOTE! Follow the recommended procedure in the order shown.

CAUTION! The Start-up procedures assume that all steps in Proportioner purging have been performed and no problems were found.

1. Check the lube fluid level and service as required.
2. Make sure the materials have been stored at the manufacturer's recommended temperature. Ask your material supplier for information (Material Safety Data Sheet) on the minimum storage temperature.
3. Y-Strainer screens should be checked routinely.
4. Connect air supply to the two Transfer Pumps and ensure Air Valves are in the full OPEN position. OPEN both Proportioner Material Inlet Ball Valves.

CAUTION! Remove all Heated Hose sections from coiled storage and lay flat to eliminate heat build-up and possible Heated Hose failure.

5. Turn ON Main Power (Item S, page 16).
6. Turn ON Control Power (Item U, page 16).
7. Turn ON Hose Heater (Item X, page 16) and confirm material set-point temperature as recommended by the material supplier or application conditions.

CAUTION! To avoid excessive pressure in the Proportioner, wait for the Hose Heater to reach its set-point temperature before continuing.

8. Turn ON each Primary Heater and confirm material set-point temperature as required by the material supplier or application conditions has been reached.
9. Set Pump Switch (Item T, page 16) to NORMAL. One of the Directional Indicator Lights (Item R, page 16) will illuminate, indicating the Metering Pump direction, and the Metering Pump Shafts will begin to move.
11. Proceed with Installation and Start-up of the Spray Gun as per the Gun manual.

NOTE! The Material Pressure Gauges should be approximately equal and remain constant throughout the Metering Pump cycle. If not, refer to Trouble Shooting section.

10 SHUT-DOWN

10.1 SHORT-TERM

Follow the procedure below for temporary shut-downs, such as **lunch breaks**:

1. Set Pump Switch (Item T, page 16) to the OFF position.
2. Turn both "A" and "R" Heaters OFF. Hose Heater should remain ON. Never leave Proportioner ON if unattended.
3. CLOSE Spray Gun Manual Valves.

CAUTION! Excessive force opening or closing the Manual Valves may result in damage to the Manual Valves and/or Coupling Block.

10.2 LONG-TERM

Follow the procedure below for shut-downs when work is **stopped for the day**:

1. Set Pump Switch (Item T, page 16) to the RETRACT position.
2. Spray off the application surface until both Material Pressure Gauges (Items C & E, page 13) read approximately 400psi.

CAUTION! To avoid possible Proportioning Pump Seal weepage, and moisture vapor drive into the Heated Hoses, the system pressure should not be reduced to zero. It is recommended to lower the system pressure to a minimum of 400 psi (28 bar).

3. CLOSE the Spray Gun Coupling Block Manual Valves.





CAUTION! Excessive force opening or closing the Manual Valves may result in damage to the Manual Valves and/or Coupling Block.

4. Turn OFF the "A" and "R" side Heaters and Hose Heater (Item X, page 16).
5. Pull up on Air Pressure Regulator (Item H, page 13) and turn COUNTERCLOCKWISE to release pressure. Close Incoming Air Valve (Item I, page 13). This prevents remaining air from entering the machine.
6. Turn OFF the Control Power (Item U, page 16).
7. Turn OFF the Main Power (Item S, page 16).
8. Disconnect the air supply to the two Transfer Pumps and CLOSE the Proportioner Material Inlet Valves.

11 TROUBLESHOOTING

This PK Series Proportioner has been designed and built to withstand severe working conditions with a high degree of reliability, provided that it is used in a suitable application by a properly trained operator. This chapter contains information on possible faults that may interrupt the operation of the PK Series Proportioner. The information provided will serve as a guideline to detect and resolve problems. In any case, feel free to contact your authorized PMC distributor, where a qualified technician will advise you.

WARNING! Only qualified personnel should perform troubleshooting; unqualified personnel may cause damage to the unit and put the operator at risk.

	<p>To prevent possible injury caused by incorrect handling of the raw materials and solvents used in the process, carefully read the Material Safety Data Sheet (MSDS) provided by your supplier. Deal with the waste caused according to current regulations.</p>
	<p>To avoid damage caused by the impact of pressurized fluids, do not open any connection or perform maintenance work on components subject to pressure until the pressure has been completely eliminated.</p>
	<p>Use suitable protection when operating, maintaining or being present in the area where the equipment is functioning. This includes, but is not limited to, the use of protective goggles, gloves, shoes and safety clothing and breathing equipment.</p>
	<p>The equipment includes components that reach high temperatures and can cause burns. Hot parts of the equipment must not be handled or touched until they have cooled completely.</p>
	<p>To prevent serious injury through crushing or amputation, do not work with the equipment without the safety guards installed on the moving parts. Make sure that all the safety guards are correctly reinstalled at the end of the repair or maintenance work of the equipment.</p>

11.1 HEATERS

WARNING! Only qualified personnel should perform troubleshooting; unqualified personnel may cause damage to the unit, personnel, or property and put the operator at risk. The Heaters are components that reach high temperatures; you must wait until they cool before handling.

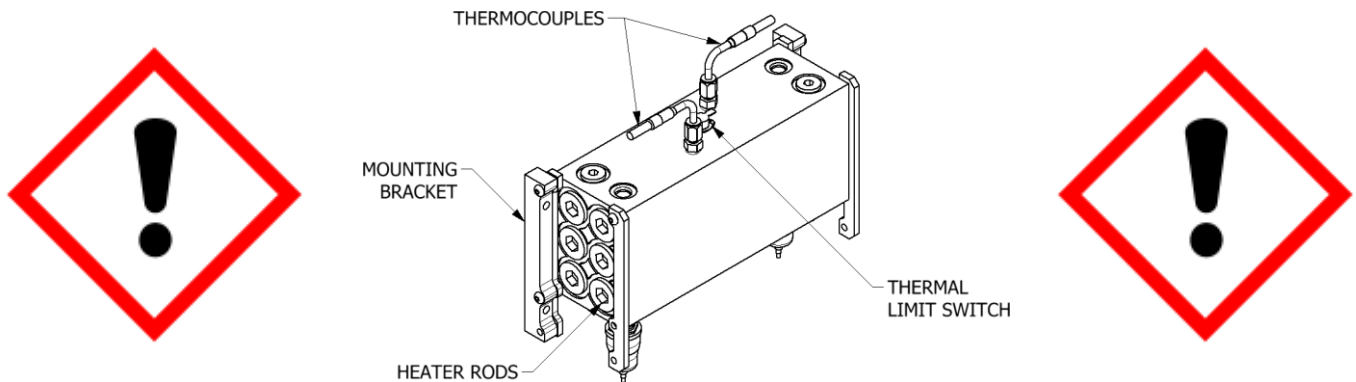

NOTE! The Thermal Limit Switch is a safety switch in contact with the Heater Body. If the surface temperature exceeds 220°F (109°C) the Limit Switch will shut off the Heater power. The Limit Switch will not re-set until the temperature in the Heater is below 190°F (88°C). The system is designed that in case of an over temperature, a contactor located in the console will open and disable power to both Heaters and the Hose.

Frequent Heater Problems

Primary heater does not heat and the display on the controller shows ambient temperature.	Page 31
Primary heater does not heat and the display on the controller shows an error message (SbEr, EEPE, CjEr, AdEr).	Page 32
Primary heater controller shows excessive temperature and the circuit has turned off.	Page 32
Primary heater Temperature drops excessively while spraying.	Page 32

Follow the recommended procedure in the indicated order to solve the problem and avoid unnecessary repairs. Make sure all Switches are in the correct position and Indicator Lights ON before determining the existence of a fault.

- **Problem:** Primary heater does not heat and the display on the controller shows ambient temperature.

Solutions:

1. Check that the light on the on/off switch is lit when the heater is turned on, if not replace the switch.

If the light is on, move to the next step.

2. Check that the Primary Heater Plug and Socket Connection is securely fastened. If the Connection is loose, wiggle and push till tight. The Connection should “click” when the Plug is fully inserted into the Socket.

If the Primary Heater Plug and Socket Connection is secure, move on to the next step.

3. Check the heater breaker in the main console and reset the breaker. If it continues to trip, wrap an Amp Clamp around one of the wires coming off the breaker. If the Amperage reading does not exceed the rating of the breaker, the breaker needs to be replaced. If the breaker draws more than its rating the most likely cause is that one or more of the fire rods located in the heater are shorted.

If the breaker is not tripped, move on to the next step.

4. Open the console top and locate the solid state relays for the heaters, looking over the console top from the front of the machine. There are two relays to the left bottom of the console, the one to the far left is for the “A” heater and the one to the right is for the “R” heater. With the heater on, look to see if an LED light is lit on the relay.

If there is no LED light on the solid state relay, move to the next step.

5. With a DC volt meter read across position A1 and A2 on the solid state relay (smaller wires) if you have a reading of 4-6 volts DC and the reading across L1 and L2 (larger wires) reads 208-230 volts AC, replace the solid state relay. With 4-6 volts DC at A1 and A2 the proper reading should be 1 volt AC across L1 and L2. A defective over temperature switch will open a contactor disabling both Heaters and the Hose.

If there is no DC voltage to the relay, move to the next step.

6. Check the M1 contactor to ensure it is activated. If not, inspect the contactor for failure.

If the M1 contactor is activated, move to the next step.

7. Using a DC volt meter, on an Eaton Controller measure across position 5 and 9 on the back of the heater controller. On an Omron Controller measure across position 5 and 6 on the back of the heater controller. This is the output of the controller and sends power to the solid state relay. On an Eaton Controller, your reading will be 4-6 volts DC. On an Omron Controller, your reading will be 12 volts DC. If there is no reading check to make sure that the set temperature of the controller is above the actual temperature reading on the controller. Before replacing the controller read across position 1 and 2 to make sure that the controller is powered up, your reading will be 208 to 230 volts AC. If there is no voltage detected; check for loose wires or a malfunction of the heater circuit breaker.

- **Problem:** Primary heater does not heat and the display on the controller shows an error message (SbEr, EEPE, CjEr, AdEr).

Solutions:

1. Check position 11 and 12 on the heater controller for loose wires.
If the wires are tight, move to the next step.
2. Remove the heater cover and check that the thermocouple wires are secure to the harness going up to the controller.
If there are no loose connections replace the heater thermocouple.

- **Problem:** Primary heater controller shows excessive temperature and the circuit has turned off.

CAUTION! The heater must be allowed to cool down before continuing.

Solutions:

1. Set the controller set point at least 20 degrees lower than the temperature shown on the controller. Briefly turn on the heater and look for the LED light on the solid state relay to be on.
If the light is on, replace the controller.
If the light is off, replace the solid state relay.

- **Problem:** Primary heater Temperature drops excessively while spraying.

Solutions:

1. Temperature of the chemical in the containers is too cold.
2. Exceeding the flow rate specification of the machine. Use a smaller mixing chamber to reduce flow.
3. Disconnect power to the machine. One or more of the fire rods in the heater have malfunctioned. Remove the heater cover and disconnect the wires to measure the resistance across each rod. Installing a smaller mixing chamber in the gun may allow you to spray until a new rod(s) is installed.

CAUTION! If the rod that is used in conjunction with the thermocouple is defective, do not operate the heater until the rod is replaced.

Individual Ohm Measurement

1250 WATT	37 OHMS
1500 WATT	31 OHMS
1750 WATT	27 OHMS

11.2 PNEUMATIC DRIVE SYSTEM

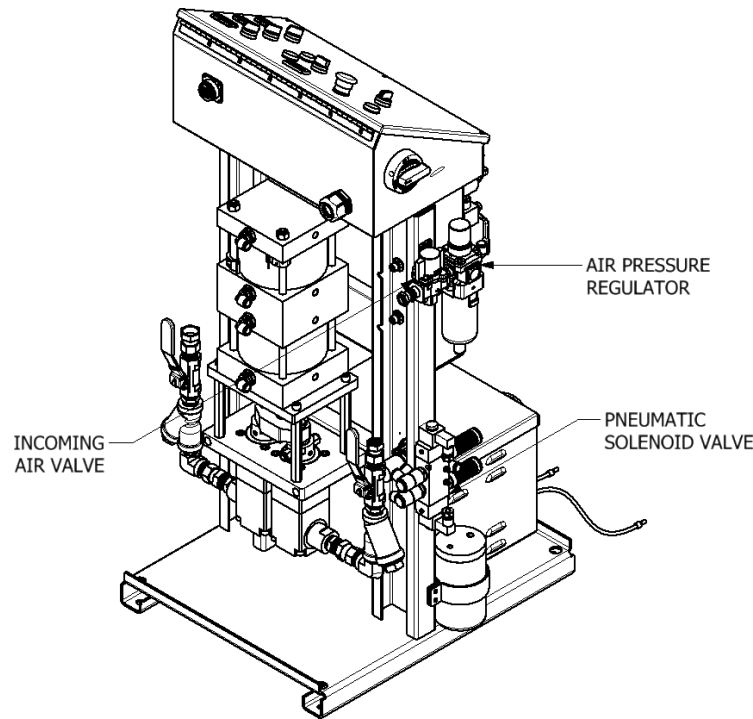

Figure 9: Pneumatic Drive System

Frequent Pneumatic Drive System Problems

Pumps have stalled and pressure is lower than normal.	Page 34
Pumps have stalled and pressure is higher than normal.	Page 34

Follow the recommended procedure in the indicated order to solve the problem and avoid unnecessary repairs. Make sure all Switches are in the correct position and Indicator Lights ON before determining the existence of a fault.

WARNING! Only qualified personnel should perform troubleshooting; unqualified personnel may cause damage to the unit, personnel, or property and put the operator at risk. The Heaters are components that reach high temperatures; you must wait until they cool before handling.

CAUTION! Excessive force opening or closing the Manual Valves may result in damage to the Manual Valves and/or Coupling Block.

- **Problem:** Pumps have stalled and pressure is lower than normal.

Solutions:

1. Confirm that the Incoming Air Valve (Item I, page 13) is in the OPEN position.
2. Check the incoming air supply to the Proportioner. The 1/2" poly hose before the Air Regulator must have between 80 - 100 psi (5.5 - 6.9 bar) to build sufficient pressure to operate the machine.
If the air supply is between 80 - 100 psi (5.5 - 6.9 bar), move to the next step.
3. Confirm that the Pneumatic Solenoid Valve has approximately 24 Volts DC supplied to it. The Pneumatic Solenoid Valve (Item F, page 13) acts as a normally closed valve and must be electrically activated to supply air to the Multi Stage Air Cylinder.
If the Pneumatic Solenoid Valve does have a proper voltage reading, move to the next step.
4. Turn power to the machine OFF and CLOSE the incoming air supply, remove the 1/2" poly tubes from the outlet side of the Pneumatic Solenoid Valve. Poly tubes can be removed from their Pneumatic Fittings by pressing in on the outer ring of the fitting while pulling the tube out. Turn the power to the machine ON and OPEN the air supply. If no air is coming from the outlet side of the Pneumatic Solenoid Valve, replace the valve.
If the Pneumatic Solenoid Valve is working properly, move to the next step.
5. The Multi Stage Air Cylinder is defective; contact your local PMC Distributor to inquire about a replacement.

-
- **Problem:** Pumps have stalled and pressure is higher than normal.

Solutions:

If one of the chemical gauges reads high and the other low than you need to balance the pressures, open the manual valve on the side that has the higher reading. This will drop the pressure on the high side and bring up the pressure on the low side, when the pressures are within 200 psi (13.8 bar) of each other close the manual valve. If the problem continues refer to the troubleshooting section of the metering pump line or the spray gun manual.

NOTE! Power to the Pneumatic Solenoid Valve will be interrupted if one or both chemical pressures have exceeded the factory pressure setting of the high pressure shut off switches; this condition will shut off the air to the outlet side of the solenoid valve.

11.3 METERING PUMP-LINE

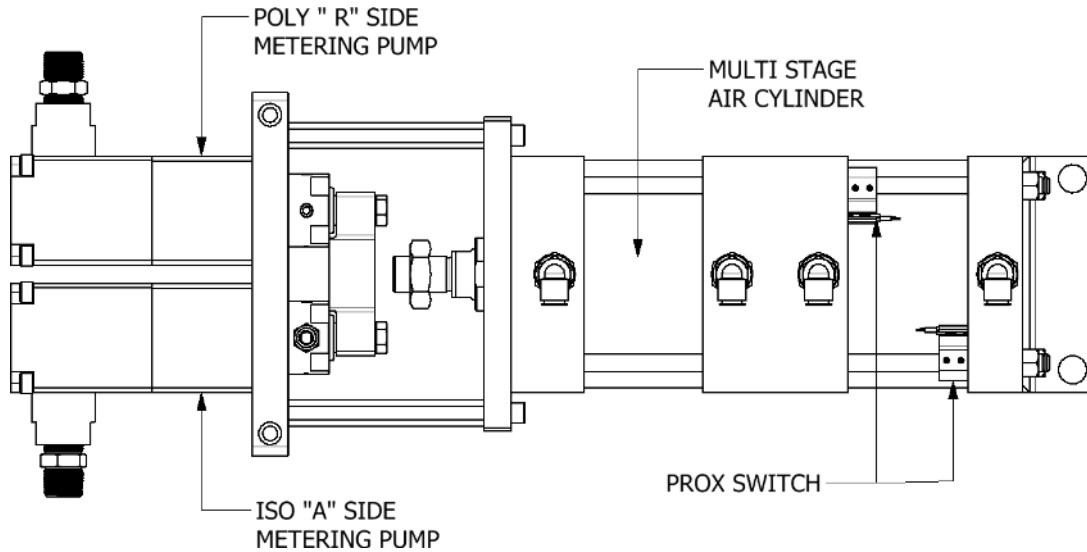

Figure 10: Metering Pump-Line (202879)

Frequent Pump-Line Problems

Metering pumps do not change direction and the pressures on both of chemical gauges are lower than normal.	Page 35
Cavitation.	Page 36
Pressure/Material Imbalance.	Page 37

Follow the recommended procedure in the indicated order to solve the problem and avoid unnecessary repairs. Make sure all Switches are in the correct position and Indicator Lights ON before determining the existence of a fault.

- **Problem:** Metering pumps do not change direction and the pressures on both of chemical gauges are lower than normal.

Solutions:

1. The Metering Pump Line has Reversing Plates which actuates two Proximity Switches, one at each end of the stroke. The Prox Switches in turn actuate the appropriate Directional Valve Solenoid (HI-05003). Failure to make contact with either Prox Switch may be caused by:
 - a. Prox Switches improperly aligned.

Each Prox Switch will be labeled either “NORMAL” or “RETRACT” to match with the corresponding stroke of the Metering Pump. “NORMAL” corresponds to the intake stroke of the Metering Pump and “RETRACT” corresponds to the discharge stroke of the Metering Pump.

At the end of each stroke, one of the Prox Switches should illuminate. If the appropriate Prox Switch is not illuminating, use a stubby flat head screwdriver to loosen the set screw for the Prox Switch housing and slightly slide back and forth until it illuminates. Tighten the set screw for the housing to lock the Prox Switch in place.

- b. Prox Switch not receiving power.

Check that the cable coming from the Prox Switch that is not activating is securely fastened to the rest of the cable that runs back to the Console. The cable has a knurled section that screws together with the matching end of the cable.

If the Prox Switches are functioning properly, move to the next step.

2. Check that the Pneumatic Solenoid Valve is functioning properly based on procedure in Hose Heating troubleshooting.

If the Pneumatic Solenoid Valve is functioning properly, move on to the next step.

3. Safety Pressure Switch.

Each Metering Pump has a Safety Pressure Switch set to 2,200 psi. for # 123 pumps, 3,200 psi for #61 pumps. When the material system reaches this pressure, the Safety Pressure Switch will remove power from the Directional Valve and Direction Indicator Lights (Item R, page 16). Lack of Direction Indicator Lights along with high pressure indicated on one or both of the material Pressure Gauges (Items C & E, page 13) is an indication of an over-pressure condition. The Safety Pressure Switches are a momentary design; when the pressure bleeds off the Metering Pump Line will resume normal operation. However, the cause of the over-pressure should be determined and corrected. The most common causes are:











- a. Cavitations of the Metering Pump on the **low** pressure side causing high pressure on the opposite side.
- b. A restriction in the Spray Gun on the **high** pressure side.
- c. Incoming air pressure is too high.

- **Problem:** Cavitation.

Solutions:

1. Cavitations occur when the Metering Pump requires a larger volume of material than the supply system (Transfer Pump) can furnish. This creates a "void" of material in the Metering Pump. The most common causes of cavitations are:
 - a. Material temperature too low causing increased material viscosity resulting in the inability of the Transfer Pump to maintain sufficient supply to the Metering Pump. This is most common with today's blowing agents. Ensure the material temperature in the drums is no lower than the material suppliers' recommendation.
 - b. Failure to vent the material drum while drawing material out with the Transfer Pump causes a vacuum and cavitations in the Transfer Pump. Ensure the drum is

- vented to the atmosphere or a Desiccated Air Dyer Kit is installed as recommended by the material supplier.
- c. Insufficient air volume for Transfer Pump or a partially closed Transfer Pump Air Valve will limit the ability of the Transfer Pump to operate at its maximum capability.
 - d. Inlet Material Screen (Item Q, page 14) obstructed.
 - e. Metering Pump Inlet Ball does not seat properly allowing material to flow back into the Material Delivery Hose when the Metering Pump is on the "Discharge" stroke. This causes the volume of material on that Metering Pump to be less on the discharge stroke resulting in intermittent off-ratio material and Pressure Gauge fluctuation.
- **Problem:** Pressure/Material Imbalance
 1. Troubleshooting this problem requires the applicator to:
 - a. Know what the NORMAL spray pressures are for the application in progress.
 - b. Determine what material is NOT exiting the Mixing Chamber.
 - c. Read the Pressure Gauge on the problem side and interpret the reading.

Material Condition	"A" GAUGE	"R" GAUGE
NORMAL		
LACK OF ISO (A)		
LACK OF POLY (R)		
RESTRICTION OF ISO (A)		
RESTRICTION OF POLY (R)		

2. Discharge/Inlet Ball

In most cases the cause of a leaking Inlet/Discharge Ball is foreign material preventing the Ball from seating properly. If the above steps do not resolve the problem, replace the appropriate Ball. For service see MAINTENANCE: METERING PUMP-LINE (page 44).

11.4 HOSE HEATING

WARNING! Before correcting any kind of defect, make sure the Main Power Switch is OFF and incoming power is locked OFF. NEVER access the inside of the Control Panel with the Proportioner power supply ON. The Heated Hose are components which reach high temperatures; you must wait until they have cooled before handling.

CAUTION! Excessive force opening or closing the Manual Valves may result in damage to the Manual Valves and/or Coupling Block.

Hose Heating Problems

Heated Hose does not heat and the display on the controller shows ambient temperature.	Page 38
Hose does not heat and the display on the controller shows an error message (SbEr).	Page 39
Heated hose controller shows excessive temperature.	Page 40
Hose will heat but does not come up to set temperature.	Page 40

Follow the recommended procedure in the indicated order to solve the problem and avoid unnecessary repairs. Make sure all Switches are in the correct position and Indicator Lights ON before determining the existence of a fault.

- **Problem:** Heated Hose does not heat and the display on the controller shows ambient temperature.

Solutions:

1. Check that the light on the ON/OFF switch is lit when the heater is turned ON, if not replace the switch.
If the light is on, move on to the next step.
2. Check that the Hose Heater Plug and Socket Connection is securely fastened. The Connection should “click” when the Plug is inserted into the Socket. **If Hose Heater Plug and Socket Connection is securely fastened, move on to the next step.**
3. Check the Hose Heat breaker in the main console and reset the breaker. If it continues to trip, wrap an Amp Clamp around one of the wires coming off the breaker. If it does not draw more than the rated value of the breaker, the breaker needs to be replaced.
If the breaker is not tripped, move on to the next step.
4. Check the circuit breaker mounted on the transformer and reset the breaker. If it continues to trip, wrap an Amp Clamp around one of the wires from the transformer going to the heated hose. If it does not draw more than the rated value of the breaker, the breaker needs to be replaced.
If the Amp Draw is less than the rated value, move on to the next step.
5. Check that the tap setting on the transformer is set for the proper hose length.
If it is set correctly, move to the next step.

6. To check the secondary side of the transformer, you must take an AC volt reading across the two leads coming out of the transformer that are connected to the “A” and “R” hose leads. If you are reading voltage (your volt reading will vary depending on what tap setting is used), most likely the problem is in the heated hose. Either a connector has come loose or there is a broken wire.
 7. Because the gun whip takes the most abuse, it is most likely the whip that has failed. Disconnect the crossover wires on the machine end of the whip hose and connect the two wires together coming off the 50’ section. Turn on the hose heat and see if the hose heat circuit is operating; if so replace the whip. To take a continuity reading through the heated hose, one of the leads from the transformer to the “A” or “R” heated hose must be disconnected.
If no voltage is coming out of the transformer to the heated hose, move on to the next step.
 8. Open the right side of the tank (where the transformer is located) and locate the solid state relay for the hose circuit. With the hose turned on and the LED light illuminated on the relay, take a volt meter (set on DC) and measure across position A1 and A2; your reading should be **24 volts DC**. Then take an AC volts measurement across position L1 and L2 (larger wires). With the relay functioning properly you should have a 1 volt reading. If the reading is **18 to 90 volts AC**, the relay has malfunctioned and needs to be replaced. If the AC Reading across L1 and L2 is **.025 volts AC** check the over temperature switches in the heaters. A defective over temperature switch will open a contactor disabling both Heaters and the Hose.
If there is no light on the solid state relay, move to the next step.
 9. Using a DC volt meter, measure across position 3 and 4 on the back of the hose controller. This is the output of the controller and sends power to the solid state relay. Your reading will be **24 volts DC**. If there is no voltage, check to make sure that the set temperature of the controller is above ambient temperature. Before replacing the controller, read across position 1 and 2 to make sure that the controller is powered up; your reading will be **208 to 230 volts AC**.
- **Problem:** Hose does not heat and the display on the controller shows an error message (SbEr).
Solutions:
 1. Check position 11 and 12 on the heater controller for loose wires.
If the wires are tight, move to the next step.
 2. Remove the transformer cover and check that the thermocouple wires are secure to the harness going up to the controller. If there are no loose connections, disconnect the wire from the TSU and connect it directly to the thermocouple harness coming out of the hose transformer.
If the controller still shows the error code, replace the hose thermocouple. If the error code goes away and temperature is now shown on the display of the controller, then all the TSU harnesses from the TSU to the transformer need to be checked for loose connectors or one or more of the harnesses are defective.

- **Problem:** Heated hose controller shows excessive temperature.

Solutions:

1. Set the controller set point at least 20 degrees lower than the temperature shown on the controller. Briefly turn on the hose and look for the led light on the solid state relay to be on.

If the light is on, replace the controller.

If the light is off, replace the solid state relay.

- **Problem:** Hose will heat but does not come up to set temperature.

Solutions:







1. Check the tap setting on the transformer to ensure that the correct position has been selected for the length of hose being used. Depending on the machines incoming voltage, you may have to move the tap setting higher (up one).

CAUTION! Do not exceed the trip value of the transformer hose breaker.

WARNING! Before correcting any kind of defect, make sure the Main Power Switch is OFF and incoming power is locked OFF. NEVER access the inside of the Control Panel with the Proportioner power supply ON.

12 MAINTENANCE

To achieve maximum output from the PH Series Proportioner, a daily or regular maintenance schedule is required.

	<p><i>To prevent possible injury caused by incorrect handling of the raw materials and solvents used in the process, carefully read the Material Safety Data Sheet (MSDS) provided by your supplier. Deal with the waste caused according to current regulations.</i></p>
	<p><i>Disconnect the unit from the power supply before carrying out any operation inside the electrical console. The electrical maintenance of the machine must only be performed by a qualified electrician.</i></p>
	<p><i>To avoid damage caused by the impact of pressurized fluids, do not open any connection or perform maintenance work on components subject to pressure until the pressure has been completely eliminated.</i></p>
	<p><i>Use suitable protection when operating, maintaining or being present in the area where the equipment is functioning. This includes, but is not limited to, the use of protective goggles, gloves, shoes and safety clothing and breathing equipment.</i></p>
	<p><i>The equipment includes components that reach high temperatures and can cause burns. Hot parts of the equipment must not be handled or touched until they have cooled completely.</i></p>
	<p><i>To prevent serious injury through crushing or amputation, do not work with the equipment without the safety guards installed on the moving parts. Make sure that all the safety guards are correctly reinstalled at the end of the repair or maintenance work of the equipment.</i></p>

CAUTION! All repairs performed by unqualified personnel or the use of parts other than supplied by PMC may cause damage to the unit and put the operator at risk.

12.1 INLET MATERIAL SCREENS

Inspection of the Inlet Material Screens on a daily basis is no longer necessary as long as the following conditions are met.

1. Material drums are stored within the recommended material storage temperature range and drums are not opened prior to installing the Proportioner Material Transfer Pumps.
2. Desiccant air dryers are used to dry replacement air as material is removed from the drums to the Proportioner.
3. Consolidation of old material into a common drum for use is minimized, especially the Iso ("A" Side).

If the above conditions are met, inspection of the Inlet Material Screens may be done on a **bi-weekly** basis.

NOTE! Inspect and clean Inlet Material Screens before Proportioner start-up. They should not be cleaned after the days' operation as the Proportioner should be purged (see page 23) immediately after inspection and cleaning. This is to reduce the risk of moisture contamination, contamination through the reaction with the solvent used in the cleaning operation, and cross-over at the Spray Gun due to air entrapment.

CAUTION! Make sure the Main Power Switch is OFF and incoming power is locked OFF.

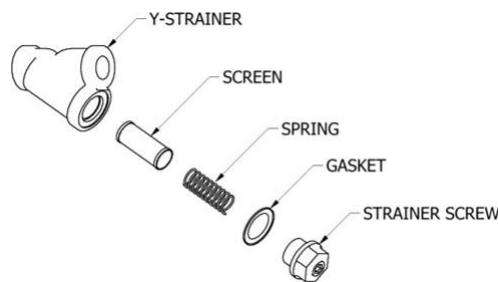

1. CLOSE the Poly ("R"-Side) Proportioner Inlet Valve.
2. Place a suitable container under the Material Inlet Strainer to collect the residual material. Carefully loosen the Strainer Plug to drain material into the container.
3. Completely unscrew the Strainer Plug.
4. Remove the Seal, Spring and Screen and clean them with a suitable solvent. Dry the parts and ensure the Screen is not obstructed. Replace the Screen if more than 20% of the Screen surface is obstructed by residue.
5. Reinstall the Screen, Spring and Seal. Screw on the Strainer Screw and screw in Plug.

6. OPEN the Poly ("R"-Side) Proportioner Inlet Valve, pressurize the Material Transfer Pump, check for leaks and wipe Y-strainer clean.
7. Repeat above for the Iso ("A"-Side) side.
8. Proceed with Proportioner Purging operation (See page 23).

12.2 ISO LUBRICATION SYSTEM

DAILY: Check the condition of the PMC Lube Oil in the Iso Lube Reservoir. Replace the PMC Lube Oil if you see significant changes in the color or signs of solidification. Ensure inside of Reservoir is wiped clean.

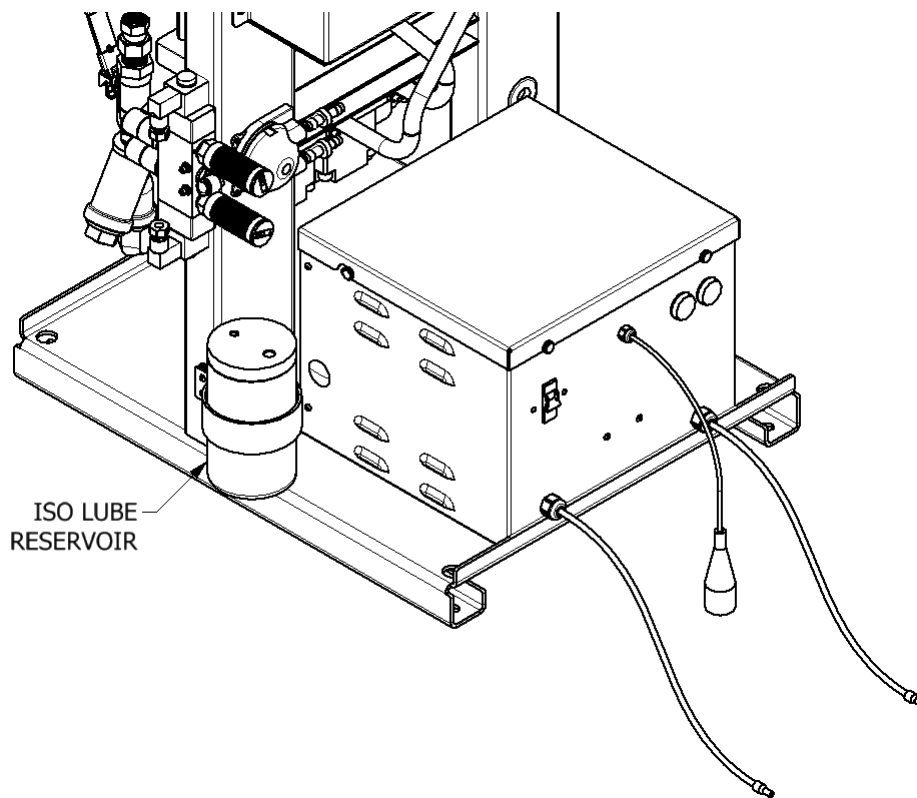

To replace the Lube Oil, proceed as follows:

1. Remove the Lube Reservoir from its support, unscrew the Lid and remove the Check Valve from the Suction Hose.
2. Empty the contaminated Lube Oil in a waste container and refit the Check Valve in the Suction Hose.

NOTE! Valve is directional.

3. Clean the Reservoir, refill with Lube Oil, and screw on the Lid and place the Reservoir in its support.

The system is auto-suction and does not need priming.

12.3 METERING PUMP-LINE

WARNING! Before performing any maintenance, make sure the Main Power Switch is OFF and incoming power is locked OFF. Allow material temperature to cool below 80°F and bleed all material pressure to zero.

Weekly: When the Proportioning Pumps are functioning properly it is not unusual for a small amount of Poly (R) material to appear on the Pump Shaft. This material should be wiped away so dirt does not accumulate on the Pump Shaft and the Pump Shaft Packings are not damaged.

Yearly or as required: It is not unusual for those who use the PK Series Proportioner on a regular basis to rebuild the Proportioning Pumps on a yearly basis.

12.4 PUMP SEAL REPLACEMENT

The pump rebuild kit part number for low pressure pumps is KT-PA and for high pressure pumps is KT-PAX.

NOTE!

- When Iso (A) Proportioning Pump Cylinder is disassembled for service, all parts included in the Seal Kit (KT-PAX) should be replaced.
- When the Poly (R) Proportioning Pump Cylinder is disassembled for service, all parts included in the Seal Kit (KT-PAX) should be replaced.
- When assembling Proportioning Pump, lubricate all Seals, Piston Rod, and Pump Cylinder with # 1 Lithium Grease to assist in assembly and minimize Seal damage during re-assembly.

CAUTION! Use wooden or plastic tools or a brass brush for cleaning. Do not use metal or abrasive tools that can scratch the contact surfaces.

12.5 MATERIAL HEATER

WARNING! Before performing any maintenance, make sure the Main Power Switch is OFF and incoming power is locked OFF. NEVER access the inside of the Control Panel with the Proportioner power supply ON. The Heaters are components that reach high temperatures; you must wait until they have cooled before handling and bleed all material pressure to zero.

12.6 THERMOCOUPLE REPLACEMENT

NOTE! The Thermocouple is assembled into the Connector Body with a Ferrule and Nut. Once inserted into the Body and the Nut is tightened, the Ferrule locks to the Thermocouple and does not allow it to be re-located or moved. The location of the Thermocouple is very important and must be done correctly before tightening the Nut.

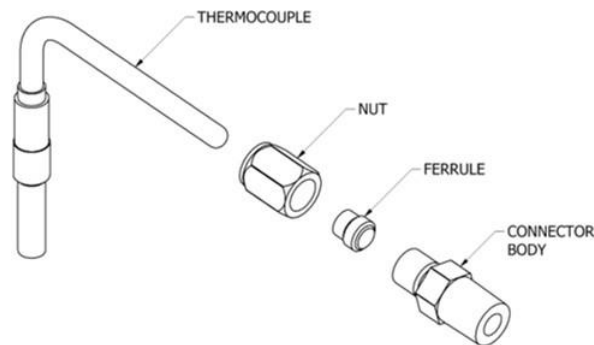

1. Unscrew the Nut that holds the defective Thermocouple and remove from the Body. Disconnect Thermocouple wiring located under the Console. Remove Body and discard.
2. Install Heating Element and Spring if also removed.
3. Install Connector Body into Heater using an open-end wrench and tighten to prevent leakage. Teflon Tape or appropriate Thread Sealant should be used.
4. Slide the Nut and the Ferrule over the Thermocouple and insert this assembly into the Connector Body until it comes into **positive physical contact** with the Heating Rod. Make sure the Spring does not prevent the Thermocouple from making contact with the Heating Rod.
5. Slowly tighten the Nut using an open-end wrench, ensuring the Thermocouple maintains positive physical contact with the Heating Rod.
6. Reinstall the Thermocouple wires.

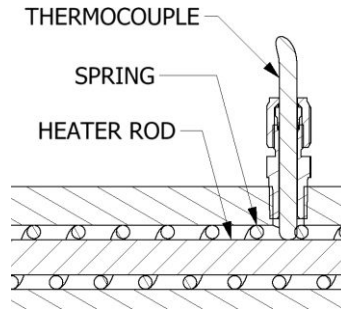

WARNING! Before performing any maintenance, make sure the Main Power Switch is OFF and incoming power is locked OFF. NEVER access the inside of the Control Panel with the Proportioner power supply ON. The Heaters are components that reach high temperatures; you must wait until they have cooled before handling and bleed all material pressure to zero.

To replace a defect Heating Rod, proceed as follows:

1. Ensure Main Power Switch is OFF and incoming power is locked OFF. Depressurize proportioner and remove the Cover on Heater.

WARNING! If the Heating Rod to be replaced is the one in contact with the Thermocouple, it is necessary to remove the Thermocouple first. Do not loosen or tighten Thermocouple Body.

2. Disconnect the suspect Heating Rod from the wire connections and test the Heating Rod again for proper electrical resistance.

Heating Rod	Ohm Measurement per Rod	Total Ohm Measurement per Fluid Side
1250 WATT	37.0 Ω	13.0 Ω
1500 WATT	31.0 Ω	10.8 Ω
1750 WATT	27.0 Ω	9.2 Ω

3. Unscrew the Heating Rod and remove from the Heater Block along with its Spring and inspect; it must be smooth and shiny in appearance. If it is blackened or has material adhered to it replace the Heating Rod, even if ohm reading is acceptable.
4. Apply Teflon Tape or appropriate Thread Sealant to the Heating Rod thread and assemble Heating Rod and Spring into the Heater Block. Tighten securely to 110 ft/lbs (150 Nm)
5. If necessary carefully re-install Thermocouple ensuring positive physical contact with the Heating Rod. Make sure the Spring does not prevent the Thermocouple from making contact with the Heating Rod. Tighten Nut with open-end wrench.
6. Reconnect wire connections and replace Cover.
7. Ensure Heater is full of material prior to electrical testing.

13 PARTS IDENTIFICATION

13.1 A & R SINGLE PUMP ASSEMBLY

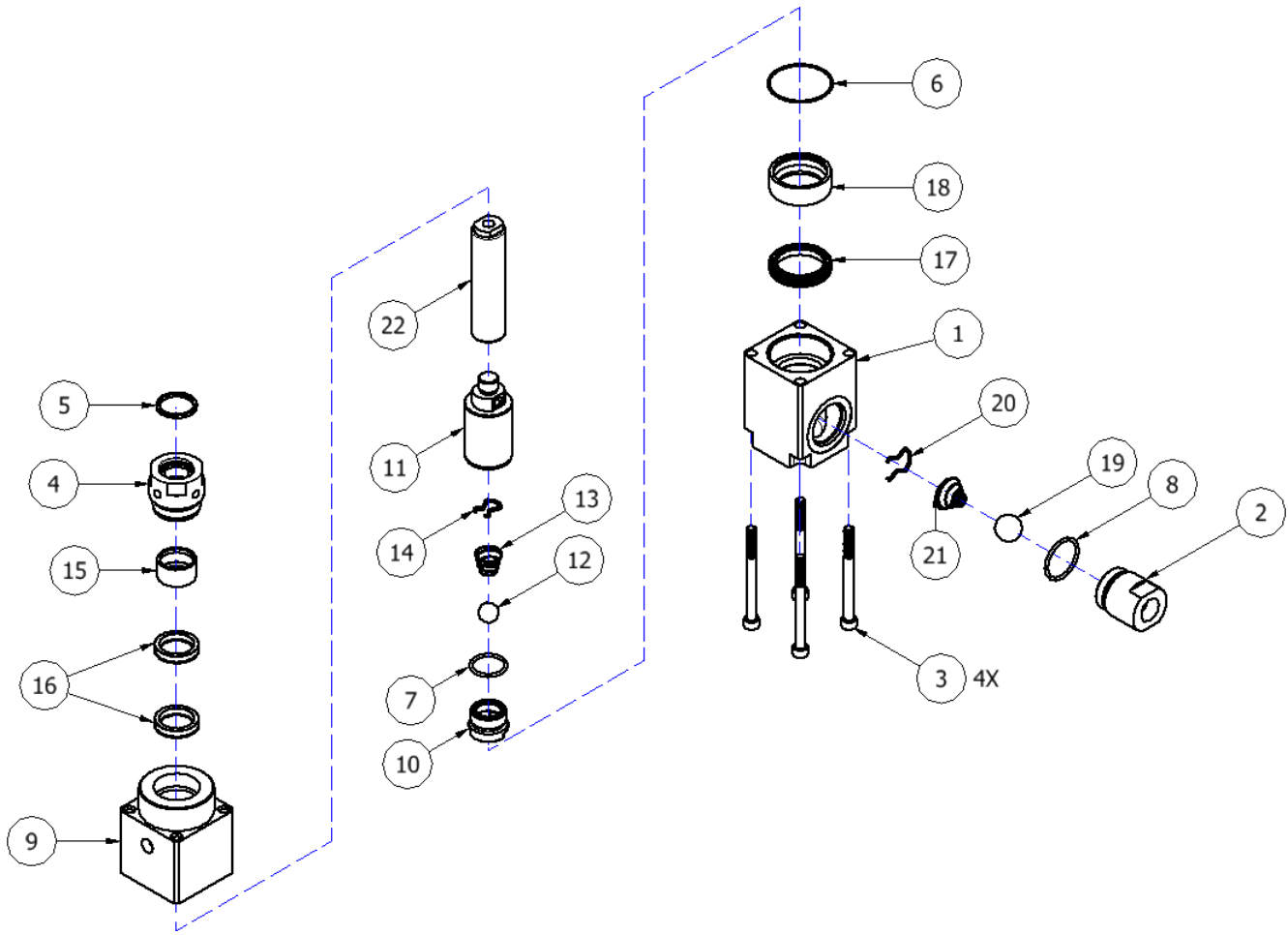

Figure 11: A & R Single Pump Assembly (202880/202881)

A & R SINGLE PUMP ASSEMBLY (202880/202881)			
ITEM	QTY	PART NUMBER	DESCRIPTION
1	1	200700	INLET BODY, LP
2	1	200701	INLET VALVE, LP
3	4	201073	SHCS, 3/8-16 X 4.000, 18-8 SS
4	1	202885	PACKING NUT
5	1	202886	SEAL, ROD, 1.25 ROD DIAMETER, POLYURETHANE
6	1	OR-035	O-RING, -035, BRN VITON
7	1	OR-916	O-RING, -916, BRN VITON
8	1	OR-920	O-RING, -920, BRN VITON
9	1	PA-045	OUTLET BODY
10	1	PA-046	PISTON VALVE
11	1	PA-047	PISTON
12	1	PA-048	3/4" CHROME BALL
13	1	PA-049	SPRING
14	1	PA-050	SPRING RETAINER
15	1	PA-051	ROD BUSHING
16	2	PA-052	ROD SEAL ASSEMBLY
17	1	PA-054	PISTON SEAL ASSY
18	1	PA-055	PISTON BUSHING
19	1	PA-059	1" CHROME BALL
20	1	PA-060	BALL STOP
21	1	PA-061	SPRING, FOOT VALVE
22	1	PA-062	FLUID ROD

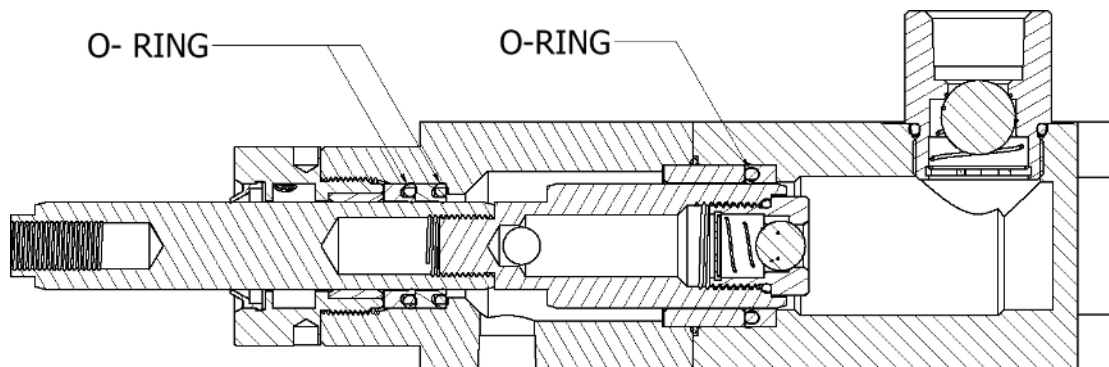

Figure 12: A & R Single Pump Cross Section

13.2 PUMP-LINE SEAL ORIENTATION

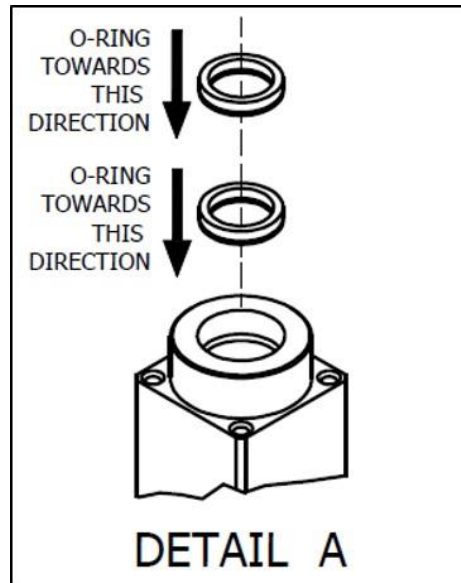

Figure 13: A & R Single Pump Assembly Detail A

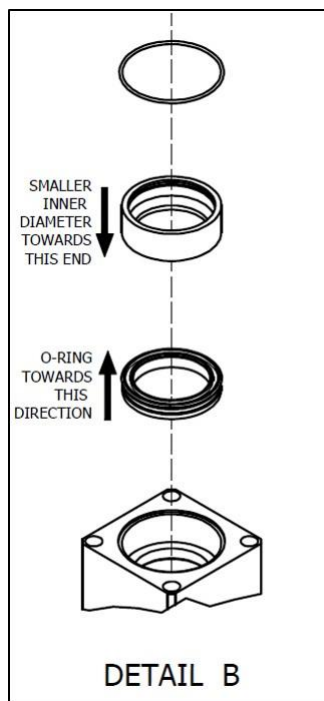

Figure 14: A & R Single Pump Assembly Detail B

13.3 PUMP-LINE ASSEMBLY

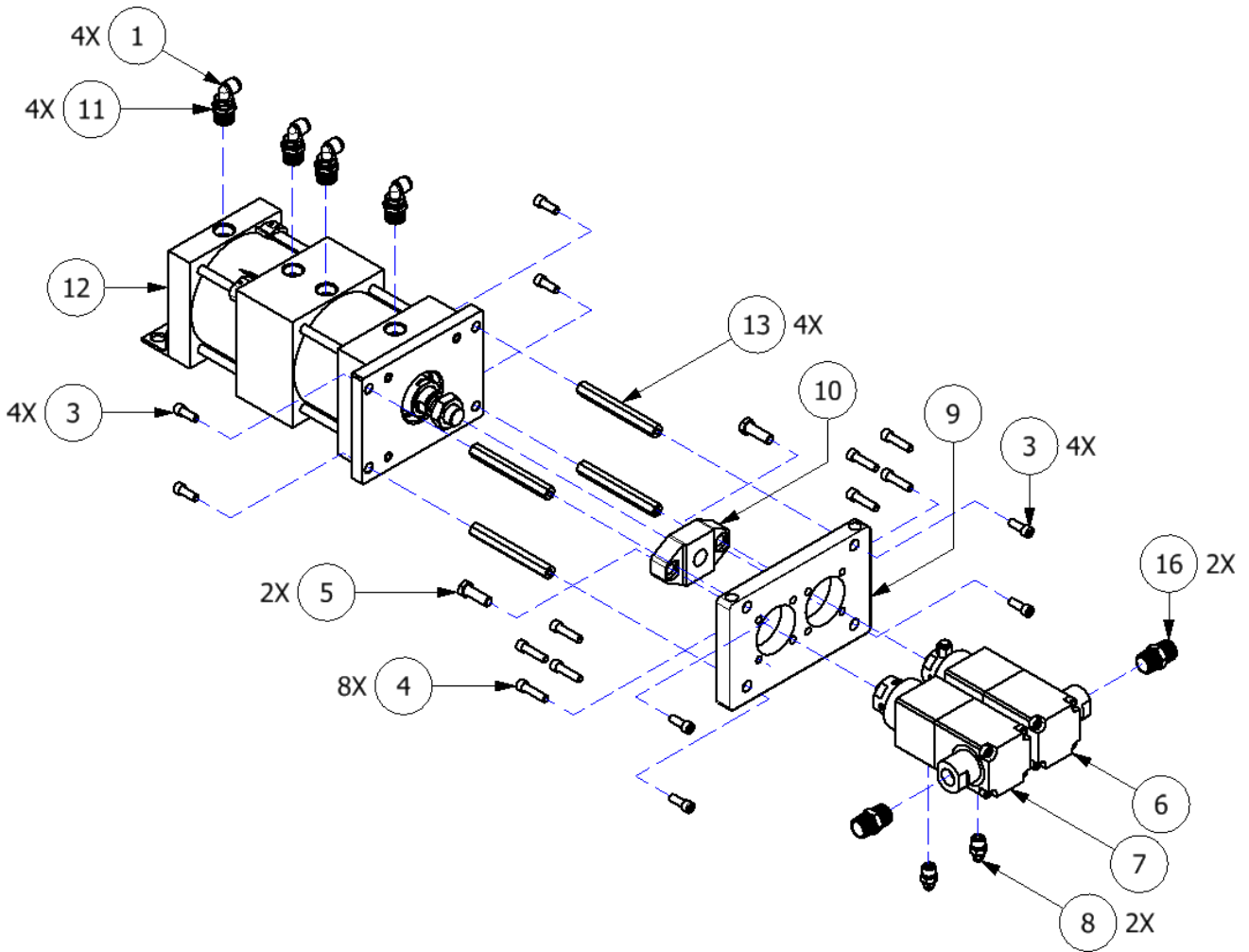

Figure 15: Pump-Line Assembly (202879)

PUMP LINE ASSEMBLY - HIGH PRESSURE (202879)			
ITEM	QTY	PART NUMBER	DESCRIPTION
1	4	201296	FTG, ELBOW, 1/2 NPT X 1/2 TUBE
2	2	201299	SHCS, 3/8-16 X 6.000, 18-8 SS
3	8	201619	SHCS, 3/8-16 X 1.000, 18-8 SS
4	8	201620	SHCS, 3/8-16 X 1.500, 18-8 SS
5	2	201622	HHCS, 1/2-20 X 1.500, 18-8 SS
6	1	202880	SINGLE PL-PA PUMP
7	1	202881	SINGLE PL-PA PUMP
8	2	202882	FTG, STRT, 3/8 NPT X -6 JIC, STL
9	1	202883	PLATE, MOUNTING, 123 PUMPS
10	1	202884	TOKE, 6IN AIR CYL, 123 PUMPS
11	4	202909	FTG, STRT, 3/4 FPTF X 1/2 MPTF, STL
12	1	202920	CYLINDER, 6IN BORE, 2 STG, 1.75 STK
13	4	202921	STANDOFF, 3/8 FEMALE, 5/8 HEX, 5 3/8 LG
14	2	202922	SOLID STATE, AUTO SWITCH
15	2	202925	MOUNTING BRACKET, AUTO SWITCH
16	2	HI-05017	FTG, UNION, 3/4 MNPTF, STL
17	6	TN-04192	PIPE PLUG, 1/8 NPT, STL

13.4 Y-STRAINER ASSEMBLY "A" SIDE

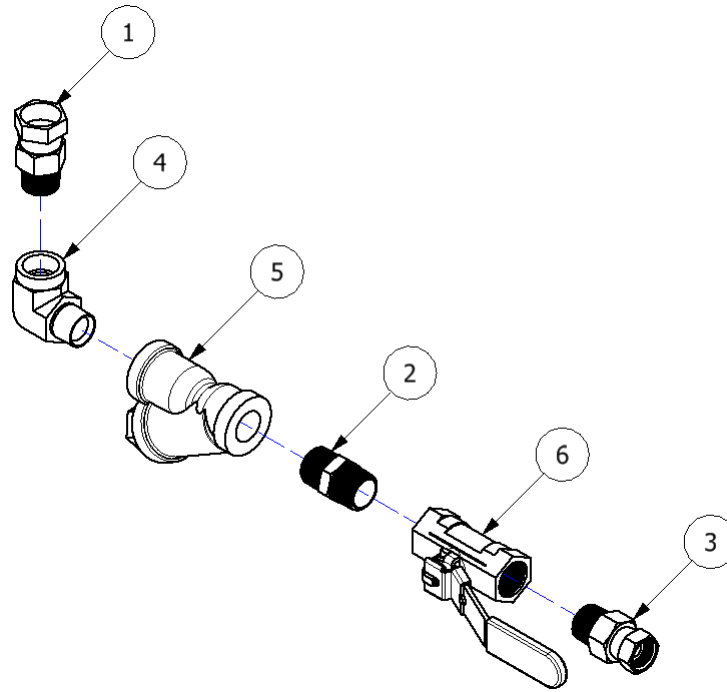

Figure 16: Y-Strainer Assembly "A" Side (202599)

Y-STRAINER ASSEMBLY "A" SIDE (202599)			
ITEM	QTY	PART NUMBER	DESCRIPTION
1	1	HI-05016	3/4 MNPT X 3/4 NPTF SW
2	1	HI-05017	3/4 MNPT UNION FTG
3	1	HI-05018	3/4 NPT X 1/2 NPT SW
4	1	HI-05093	NPTM X NPTF ELBOW
5	1	RA-00074-00A	Y-STRAINER ASSY
6	1	RA-00078A	3/4 NPT BALL VALVE, SS

13.5 Y-STRAINER ASSEMBLY "R" SIDE

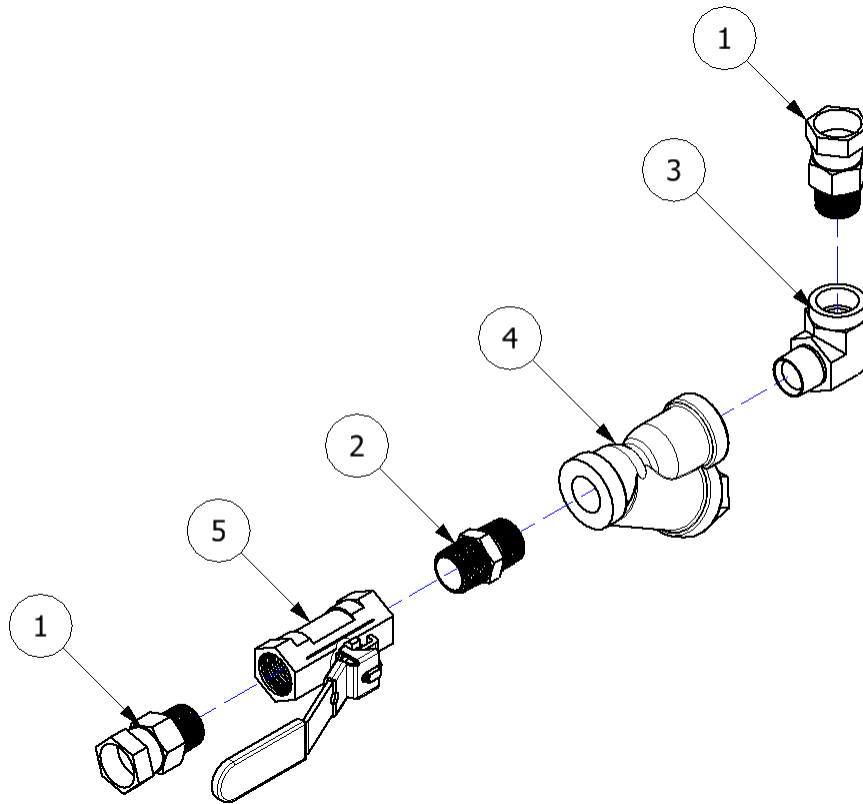

Figure 17: Y-Strainer Assembly "R" Side (202600)

Y-Strainer Assembly "R" Side (202600)			
ITEM	QTY	PART NUMBER	DESCRIPTION
1	2	HI-05016	3/4 MNPT X 3/4 NPTF SW
2	1	HI-05017	3/4 MNPT UNION FTG
3	1	HI-05093	NPTM X NPTF ELBOW
4	1	RA-00074-00A	Y-STRAINER ASSY
5	1	RA-00078A	3/4 BALL VALVE SS

13.6 HEATER ASSEMBLY

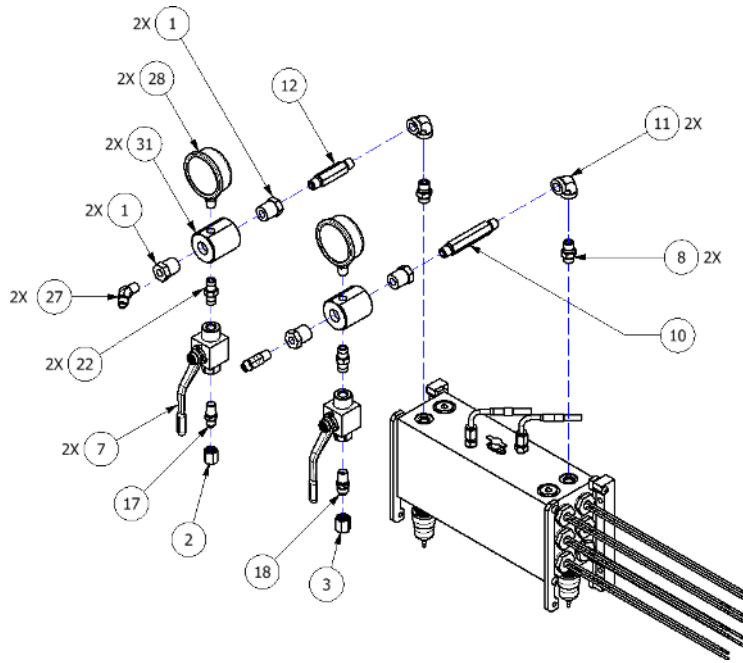

Figure 18: Heater Assembly, PK-25 - A

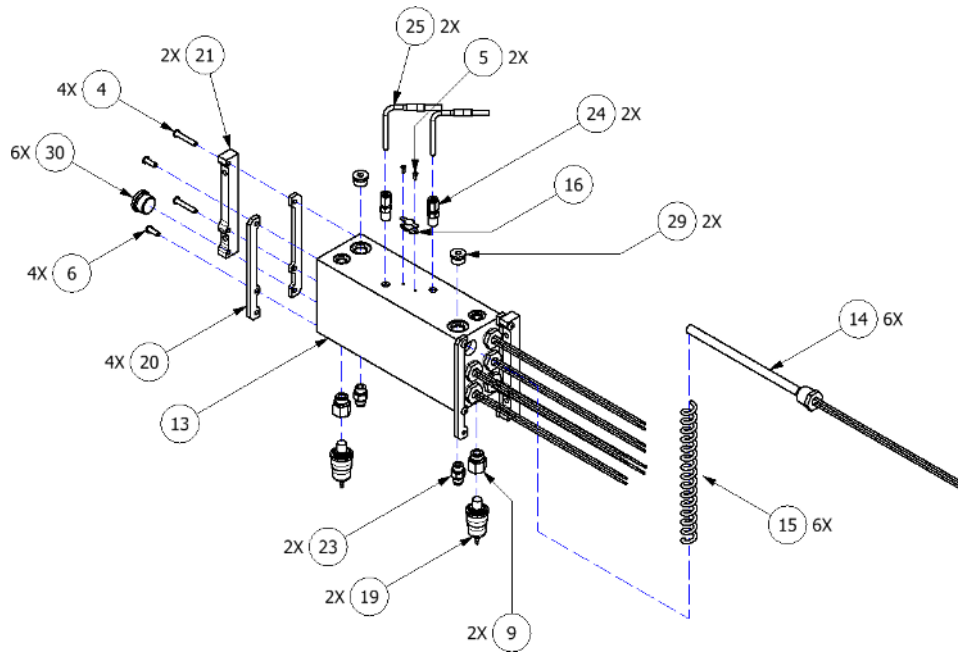

Figure 19: Heater Assembly, PK-25 - B

HEATER ASSEMBLY, 6KW, PK-25 (202870)			
ITEM	QTY	PART NUMBER	DESCRIPTION
1	4	200219	1/2 NPTF MALE X 1/4 NPTF FEMALE
2	1	202226	JIC-5 CAP
3	1	200227	JIC-6 CAP
4	4	201559	BHCS, 1/4-20 X 1.500, 18-8 SS
5	2	201561	BHCS, #6-32 X 0.375, 18-8 SS
6	4	201899	BHCS, 1/4-20 X 0.750, 18-8 SS
7	2	202430	BALL VALVE, 1/4 NPT, 5,000PSI
8	2	202636	FTG, ADAPTER, -6 ORB, 1/4 NPT
9	2	202639	FTG, ADAPTER, -8 ORB, 1/4 NPT
10	1	202844	FTG, LONG HEX NIPPLE, 1/4 MNPT X 4 LG
11	2	202845	FTG, 90 ELBOW, 1/4 FEMALE NPT
12	1	202846	FTG, LONG HEX NIPPLE, 1/4 MNPT X 3 LG
13	1	202871	HEATER BLOCK, PK-1600
14	6	202872-1250	FIRE ROD, 1250W, 3/4 NPT X 9IN LG
15	6	202873	HTR, SPRING, 12IN, CBN STL
16	1	EL-00006A	SWITCH, OVERTEMP
17	1	EL-00051A-4	FTG, 1/4 X #5 JIC MALE
18	1	EL-00051A-6	FTG, 1/4 X #6 JIC MALE
19	1	EL-52-2000	PRESSURE SWITCH
20	1	GM-07004	HTR, SPACER, 6-8 ROD
21	1	GM-07005	HTR, MOUNT, 6-8 ROD
22	1	GP-00100-1	NIPPLE, HEX, 1/4 NPT, STL
23	1	HI-05011	9/16-18 O-RING X #6 JIC NIPPLE
24*	1	HI-05020	THERMOCOUPLE, NUT, FERRULE, BODY
25*	1	HI-05021	E TYPE THERMOCOUPLE
26	1	HI-05026	1/4 NPT X 9/16-18 JIC 45 DEG
27	1	HI-05027	1/4 NPT X 1/2-20 JIC 45 DEG
28	1	HI-05028	GAUGE, PRESSURE, 0-3,000PSI
29	1	HI-05033	PLUG, -08 ORB, STL
30	1	HI-05034	PLUG, -12 ORB, STL
31	1	HI-05046-1/2	MANIFOLD, 1/2 OUTLET

* Indicates part included in KT-05021: Heater Thermocouple Kit

13.7 FINAL ASSEMBLY

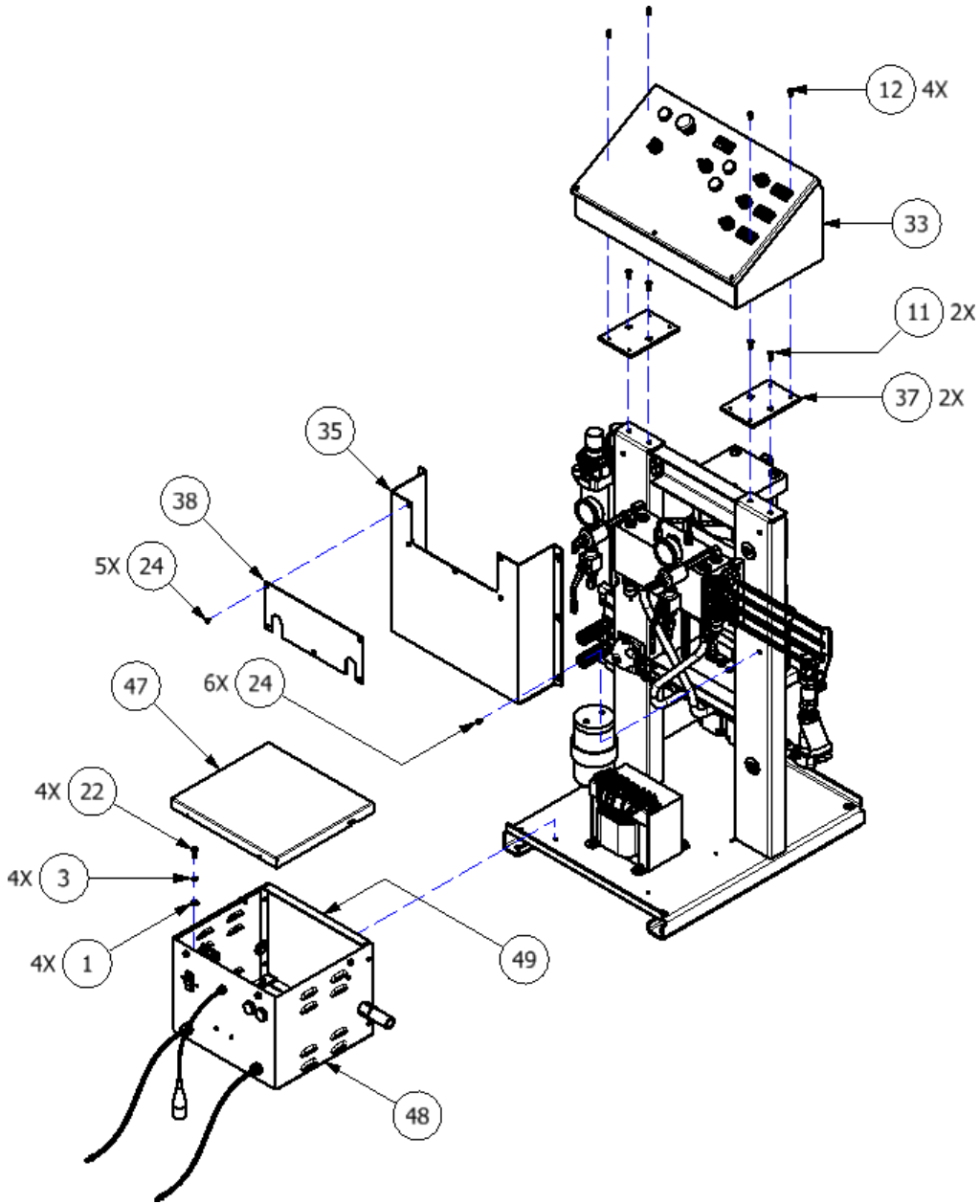

Figure 20: PK-25 Final Assembly - A

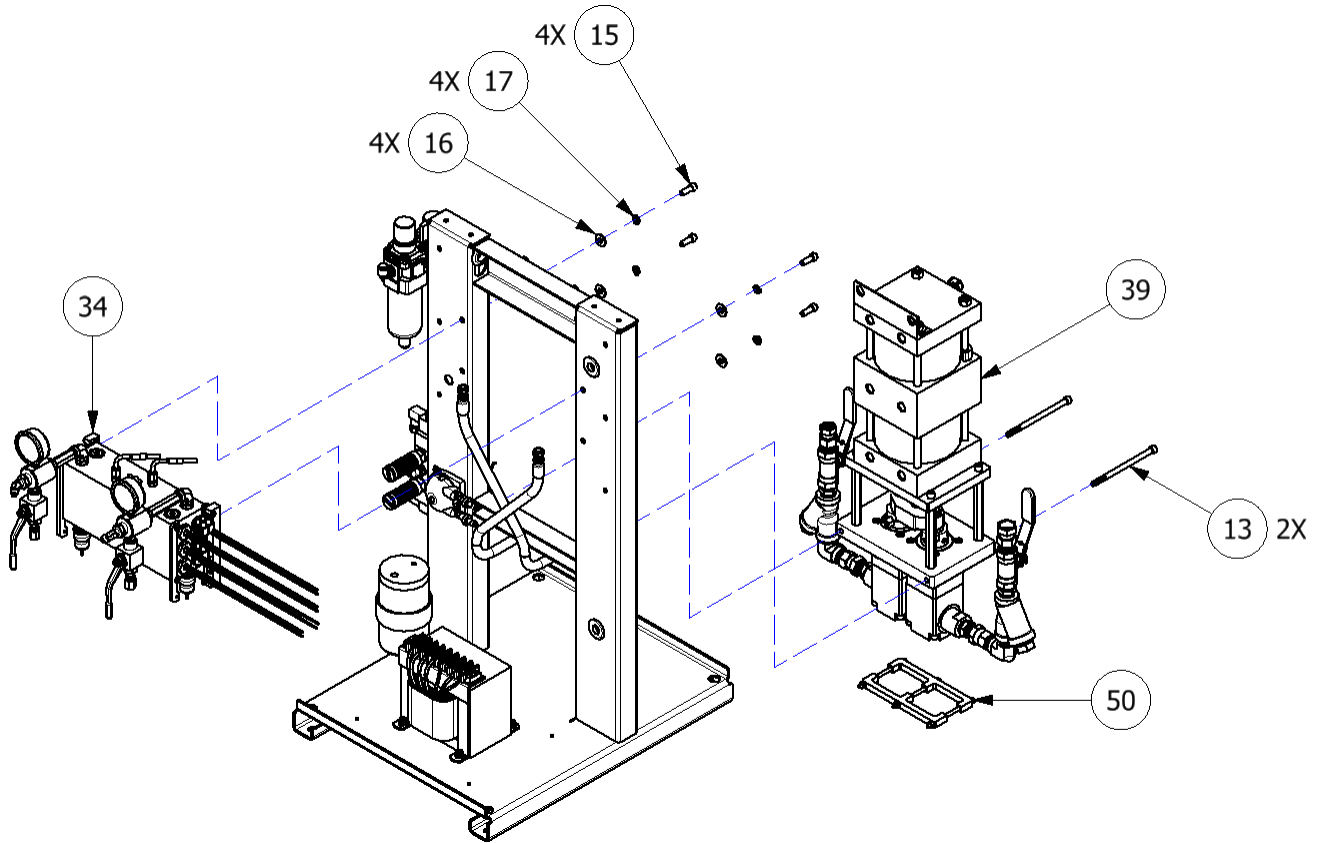

Figure 21: PK-25 Final Assembly - B

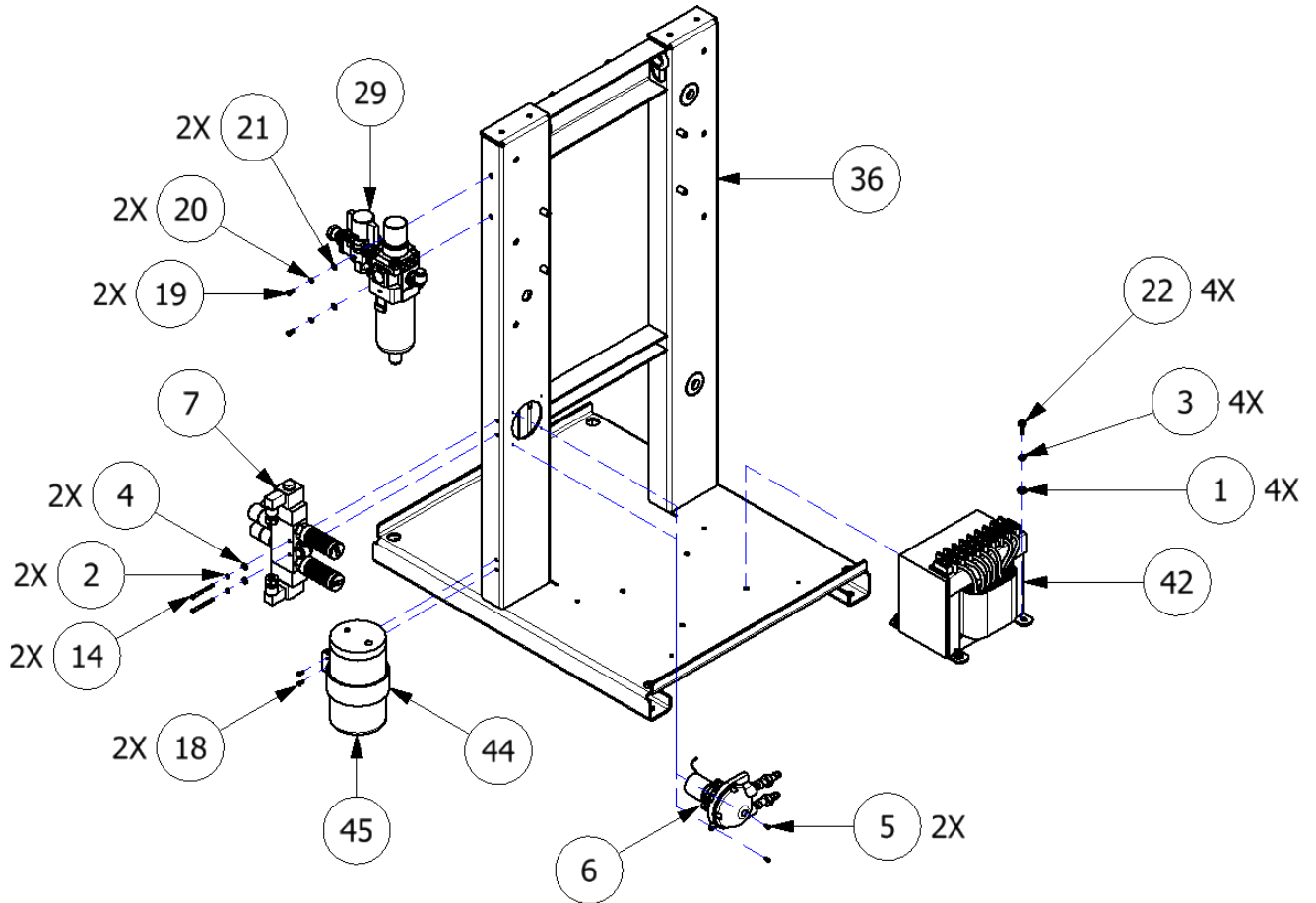

Figure 22: PK-25 Final Assembly - C

PK-25 (202867)			
ITEM	QTY	PART NUMBER	DESCRIPTION
1	8	201056	WASHER, FLAT, 1/4
2	2	201059	WASHER, LOCK, #8
3	8	201060	WASHER, LOCK, 1/4
4	2	201061	WASHER, FLAT, #8
5	2	201069	SHCS, #5-40 X 1/4, BO
6	1	201251	PUMP PERISTALTIC
7	1	201292	VALVE, PNEUMATIC, 4-WAY, 1/2 PORTS
8	2	201293	SILENCER, 1/2 NPT
9	2	201295	FTG, DOUBLE ELBOW, 1/2 NPT X 1/2 TUBE
10	2	201296	FTG, ELBOW, 1/2 NPT X 1/2 TUBE
11	4	201529	FHCS, 1/4-20 X 0.750, 18-8 SS
12	4	201560	BHCS, 1/4-20 X 0.500, 18-8 SS
13	2	201585	SHCS, 3/8-16 X 6.000, 18-8 SS
14	2	201586	SHCS, #8-32 X 1.750, 18-8 SS
15	4	201619	SHCS, 3/8-16 X 1.000, 18-8 SS
16	4	201627	WASHER, FLAT, 3/8, 18-8 SS
17	1	201628	WASHER, LOCK, 3/8, 18-8 SS
18	2	201633	BHCS, #8-32 X 0.375, 18-8 SS
19	2	201890	BHCS, #10-32 X 0.438, 18-8 SS
20	2	201891	WASHER, LOCK, #10, 18-8 SS
21	2	201892	WASHER, FLAT, #10, 18-8 SS
22	8	202146	HHCS, 1/4-20 X 0.750, ZP GRD 8
23	4	202191	BHCS, #8-32 X 0.250, 18-8 SS
24	11	202328	BHCS, #8-32 X 0.375, 18-8 SS
25	1	202552	PLUG, LOCKING, 1.000 DIA, NYLON
26	1	202599	Y-STRAINER, A-SIDE, PK-25
27	1	202600	Y-STRAINER, R-SIDE, PK-25
28	1	202613	FILTER/REGULATOR, 0-150 PSI
29	1	202614	VALVE, RELIEF, SINGLE ACTION
30	1	202615	SPACER WITH BRACKET
31	2	202847	GROMMET, 1 1/4 HOLE X 1/8 THICKNESS
32	2	202848	GROMMET, 1 3/8 HOLE X 1/8 THICKNESS
33	1	202868	CONSOLE, PK-25
34	1	202870	HEATER ASSY, 6KW, PK-25
35	1	202874	COVER, HEATER, PK-25

ITEM	QTY	PART NUMBER	DESCRIPTION
36	1	202875	FRAME ASSY, PK-25
37	2	202876	PLATE, CONSOLE TO FRAME, PK-25
38	1	202878	COVER, HEATER, TOP, PK-25
39	1	202879	PUMPLINE, 6IN 2-STAGE, 123 PUMPS
40	1	202910	FTG, 1/2 MPT X 3/8 FPT SWIVEL, STL
41	2	EL-63	PREHEATER ELECTRICAL CONNECTOR
42	1	EL-05228	70V TRANSFORMER
43	4	EL-05700-27	TRANSFORMER KNOB
44	1	MQ-01008A	LUBE BOTTLE BRACKET
45	1	MQ-01009-01A	LUBE BOTTLE
46	1	MQ-01009-02A	LUBE BOTTLE LID
47	1	RM-05700-26	TRANSFORMER COVER, TOP
48	1	RM-05700-34	TRANSFORMER COVER, SIDES
49	1	RM-06700-27	TRANSFORMER COVER, REAR
50	1	202976	PUMP CLAMP, PK-25

13.8 PK-25 HOSES

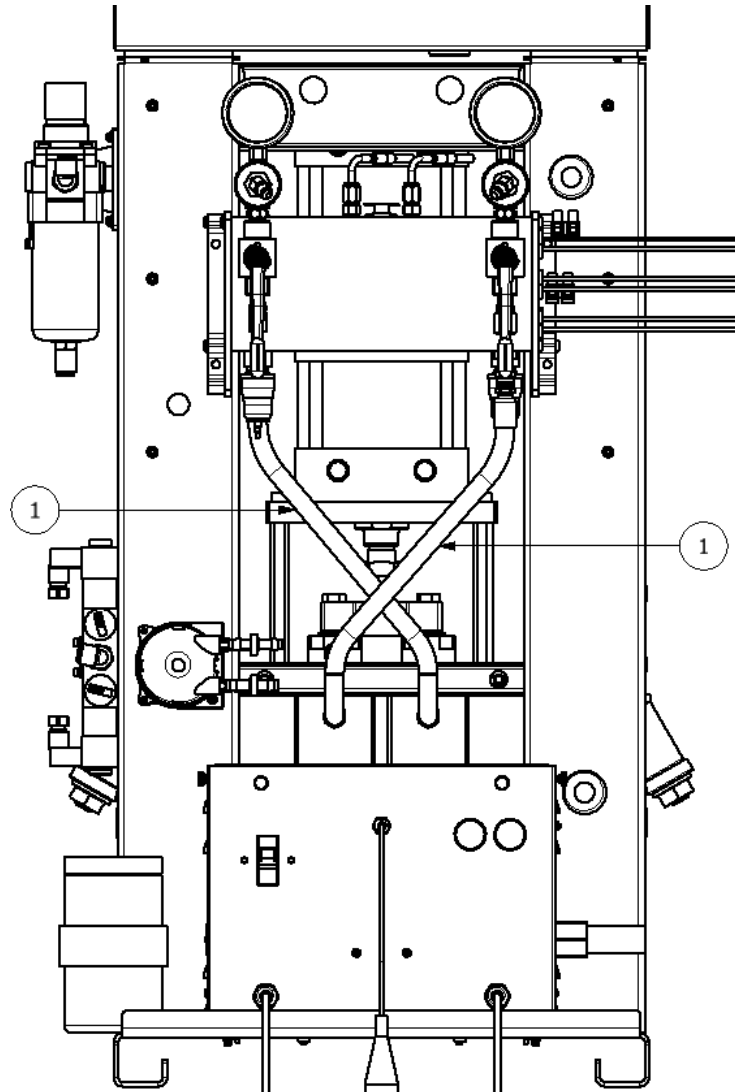

Figure 23: Proportioner Hoses

PROPORTIONER HOSES			
ITEM	QTY	PART NUMBER	DESCRIPTION
1	2	HI-05047-1	16.25" HOSE, HYD PUMP TO TANK

13.9 LUBE BOTTLE COMPONENTS

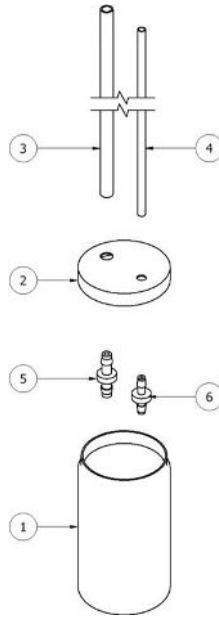

Figure 24: Lube Bottle Assembly

LUBE BOTTLE ASSEMBLY			
ITEM	QTY	PART NUMBER	DESCRIPTION
1	1	MQ-01009-01A	LUBE BOTTLE
2	1	MQ-01009-02A	LUBE BOTTLE LID
3	1	MA-00024A-1	1/2" X 43" PLASTIC TUBING, SUPPLY
4	1	MA-00025A-1	3/8" X 43" PLASTIC TUBING, RETURN
5	1	RA-00068A	CHECK VALVE
6	1	RA-06008	CHECK VALVE
-	1	GP-00960-1-GAL	PUMP LUBE GALLON
-	1	GP-00960-1-QRT	PUMP LUBE QUART

LUBE ASSY KIT (KT-05004)		
QTY	PART NUMBER	DESCRIPTION
1	RA-00068A	CHECK VALVE
1	RA-06008	CHECK VALVE
1	MQ-01009-01A	LUBE BOTTLE
1	MQ-01009-02A	LUBE BOTTLE LID
1	MA-00024A-1	1/2 X 43" PLASTIC TUBING, SUPPLY
1	MA-00025A-1	3/8" X 43" PLASTIC TUBING, RETURN

13.10 BLEED VALVE KIT

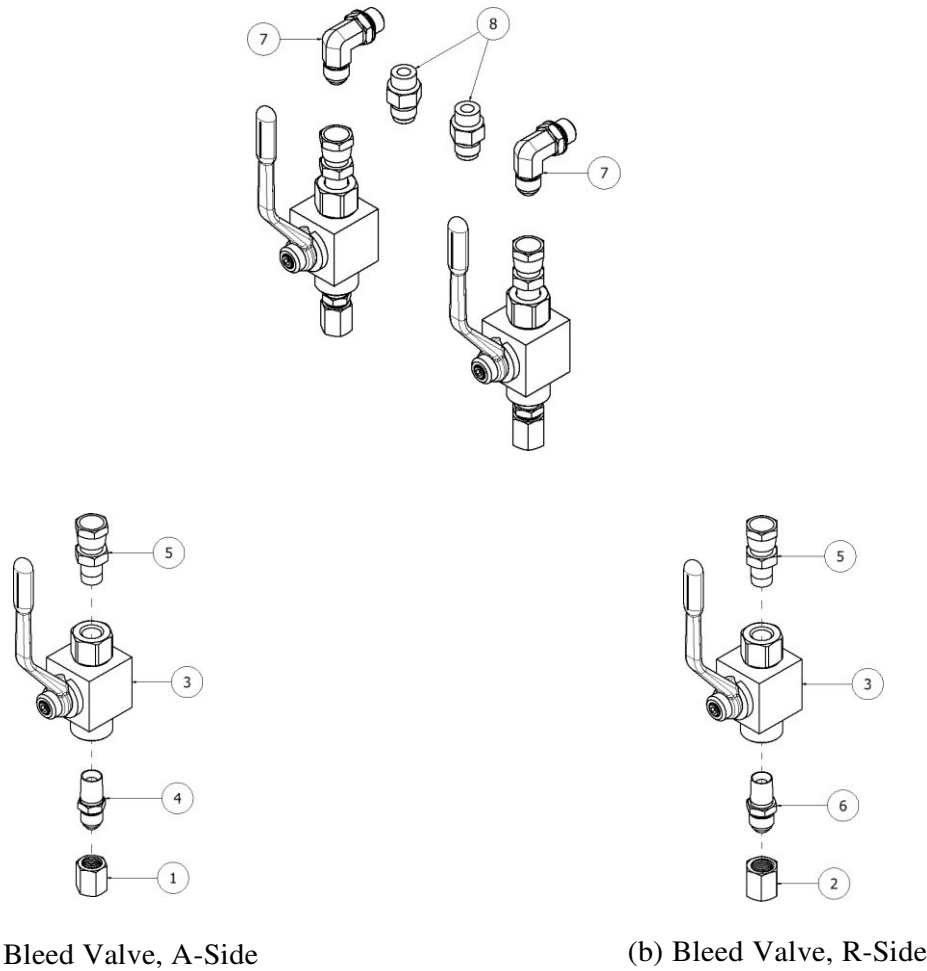

Figure 25: Bleed Valve Kit (202456)

BLEED VALVE KIT (202456)			
ITEM	QTY	PART NUMBER	DESCRIPTION
1	1	200226	5 JIC CAP
2	1	200227	6 JIC CAP
3	2	202430	BALL VALVE, 1/4 NPT, 5000 PSI
4	1	EL-00051A-4	1/4 NPT X 5 JIC
5	2	EL-00051A-5	1/4 NPT X 6 SWIVEL
6	1	EL-00051A-6	1/4 NPT X 6 JIC
7	2	HI-05007	6 ORB X 6 JIC 90 DEG
8	2	HI-05011	6 ORB X 6 JIC